

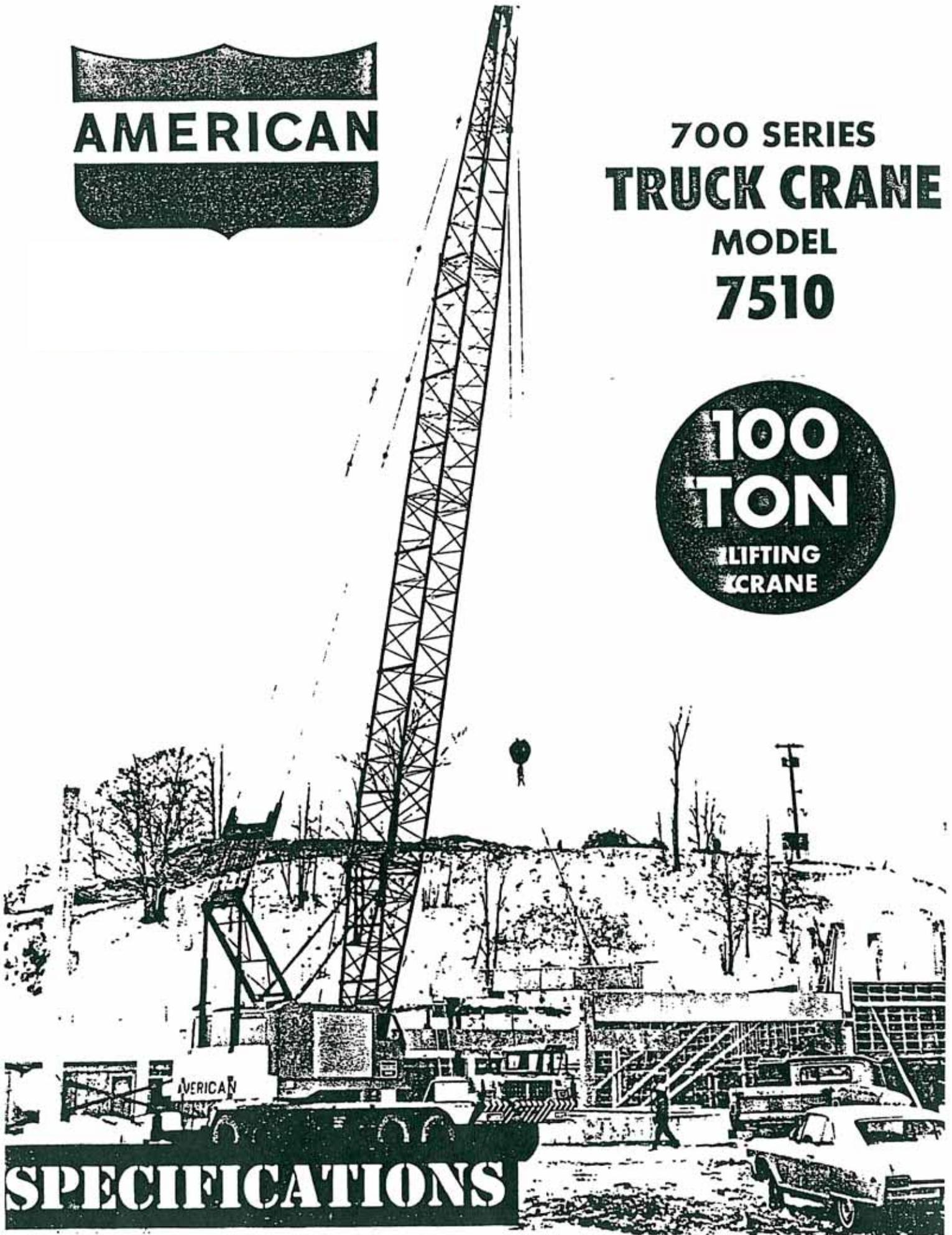

**700 SERIES
TRUCK CRANE
MODEL
7510**



SPECIFICATIONS

AMERICAN MODEL 7510 LIFT CRANE RATINGS

Hammerhead Tip

Boom Length	Radius Feet	Boom Angle Degrees	Free Over Side	Free Over Rear	Outriggers Extended and Set
40'	12	82	—	115,450	*200,000
	15	77	—	93,770	*179,010
	20	70	—	64,360	*126,710
	25	62	30,540	48,610	*97,640
	30	54	25,410	38,790	74,530
	35	44	21,580	32,070	59,130
	40	31	18,610	27,180	48,790
50'	12	84	—	114,890	*200,000
	15	80	—	93,540	*178,700
	20	74	—	64,140	*126,420
	25	68	30,180	48,400	*97,360
	30	62	25,060	38,580	74,430
	35	55	21,260	31,870	59,020
	40	47	18,310	26,990	48,680
	50	28	14,030	20,350	35,650
60'	13	84	—	110,280	*200,000
	15	82	—	93,290	*178,370
	20	77	—	63,890	*126,090
	25	72	29,780	48,150	*97,040
	30	67	24,680	38,340	74,270
	35	62	20,890	31,630	58,850
	40	56	17,960	26,750	48,510
	50	43	13,710	20,130	35,480
	60	25	10,760	15,820	27,600
70'	14	84	—	102,270	*193,940
	15	83	—	93,030	*178,030
	20	79	—	63,620	*125,750
	25	75	29,370	47,880	*96,700
	30	70	24,290	38,070	74,100
	35	66	20,510	31,370	58,660
	40	61	17,580	26,490	48,300
	50	51	13,350	19,880	35,270
	60	40	10,430	15,580	27,400
70	23	8,280	12,560	22,110	
80'	16	83	—	85,000	*164,120
	20	80	36,150	63,340	*125,400
	25	77	28,950	47,600	*96,350
	30	73	23,880	37,790	73,900
	35	69	20,110	31,090	58,450
	40	65	17,190	26,220	48,090

Boom Length	Radius Feet	Boom Angle Degrees	Free Over Side	Free Over Rear	Outriggers Extended and Set
80'	50	57	12,980	19,610	35,050
	60	48	10,070	15,320	27,170
	70	37	7,940	12,310	21,890
	80	22	6,290	10,060	18,090
90'	17	83	—	78,110	*152,090
	20	82	35,710	63,070	*125,040
	25	78	28,520	47,320	*96,000
	30	75	23,460	37,500	73,700
	35	72	19,700	30,800	58,230
	40	68	16,800	25,930	47,860
	50	61	12,600	19,320	34,810
	60	54	9,700	15,040	26,930
	70	45	7,580	12,040	21,650
	80	35	5,950	9,810	17,860
90	20	4,650	8,070	14,990	
100'	18	84	39,060	72,130	*139,050
	20	82	35,270	62,790	*124,690
	25	80	28,100	47,030	*95,640
	30	77	23,040	37,220	73,490
	35	74	19,290	30,510	58,010
	40	71	16,390	25,640	47,620
	50	64	12,200	19,030	34,560
	60	58	9,320	14,760	26,670
	70	51	7,200	11,750	21,390
	80	43	5,590	9,530	17,600
90	33	4,300	7,810	14,750	
100	19	3,250	6,430	12,500	
110'	19	84	36,640	66,880	*132,260
	20	83	34,830	62,510	*124,330
	25	81	27,670	46,740	*95,280
	30	78	22,620	36,920	73,280
	35	75	18,880	30,220	57,780
	40	73	15,980	25,350	47,380
	50	67	11,800	18,740	34,310
	60	61	8,930	14,460	26,410
	70	55	6,820	11,460	21,130
	80	48	5,210	9,240	17,340
	90	41	3,940	7,530	14,490
100	31	2,900	6,160	12,250	
110	18	2,030	5,030	10,450	

AMERICAN MODEL 7510 LIFT CRANE RATINGS

Hammerhead Tip (Continued)

Boom Length	Radius Feet	Boom Angle Degrees	Free Over Side	Free Over Rear	Outriggers Extended and Set
120'	21	83	32,730	58,350	*116,910
	25	81	27,240	46,460	*94,920
	30	79	22,200	36,630	73,070
	35	77	18,460	29,920	57,550
	40	74	15,570	25,050	47,140
	50	69	11,400	18,440	34,050
	60	64	8,530	14,170	26,150
	70	58	6,440	11,170	20,860
	80	52	4,830	8,950	17,070
	90	46	3,560	7,240	14,220
	100	39	2,530	5,870	11,990
	110	30	1,670	4,760	10,190
120	18	—	3,820	8,710	
130'	22	83	30,760	54,610	*109,880
	25	82	27,810	46,170	*94,560
	30	80	21,780	36,340	72,860
	35	78	18,050	29,630	57,320
	40	75	15,160	24,750	46,890
	50	71	11,000	18,140	33,790
	60	66	8,140	13,870	25,880
	70	61	6,040	10,870	20,590
	80	56	4,450	8,650	16,800
	90	50	3,180	6,940	13,940
	100	44	2,160	5,580	11,710
	110	37	1,300	4,470	9,920
	120	29	—	3,540	8,450
130	17	—	2,750	7,210	

Boom Length	Radius Feet	Boom Angle Degrees	Free Over Side	Free Over Rear	Outriggers Extended and Set
140'	23	84	28,910	51,230	*104,120
	25	83	26,380	45,880	*94,190
	30	81	21,360	36,050	72,650
	35	79	17,630	29,330	57,090
	40	76	14,750	24,460	46,650
	50	72	10,600	17,840	33,530
	60	68	7,740	13,560	25,610
	70	63	5,650	10,570	20,320
	80	59	4,060	8,350	16,520
	90	54	2,800	6,640	13,660
	100	48	1,780	5,280	11,430
	110	42	—	4,170	9,640
	120	36	—	3,250	8,170
	130	28	—	2,470	6,940
140	16	—	1,790	5,890	
150'	24	84	27,170	48,140	*98,570
	25	83	25,950	45,590	*93,830
	30	81	20,940	35,750	72,440
	35	79	17,210	29,040	56,850
	40	77	14,340	24,160	46,400
	50	73	10,190	17,540	33,270
	60	69	7,340	13,260	25,340
	70	65	5,250	10,270	20,040
	80	61	3,660	8,050	16,240
	90	56	2,410	6,340	13,380
	100	52	1,390	4,980	11,150
	110	47	—	3,880	9,360
	120	41	—	2,960	7,890
130	35	—	2,180	6,660	
140	27	—	1,510	5,620	
150	16	—	—	4,710	

09:22 08 19 89

Load ratings do not exceed 85% of tipping with crane standing level on firm, uniformly supporting surface. Safe loads depend on ground conditions, boom length, radius of operation, condition and inflation (100 psi) of tires, and proper handling, all of which must be taken into consideration by user. Ratings marked (*) are based on strength not stability.

"Radius in feet" is the horizontal distance at ground level from center pin to a vertical line through the center of gravity of the suspended load. Blocks, slings, buckets and other load-carrying devices are considered part of the load.

Retractable A-frame must be in fully raised position for above ratings. Free ratings do not exceed maximum permissible tire load. Free ratings are omitted where, without load, backward stability is less than industry standard.

Standard equipped crane with "K-F-L" counterweight and outriggers extended and set, will self erect 150 ft main boom with hammerhead plus 50 ft No 9 jib or 60 ft No 9HL jib.

AMERICAN MODEL 7510 LIFT CRANE RATINGS

Tapered tip

Boom Length	Radius Feet	Boom Angle Degrees	Free Over Side	Free Over Rear	Outriggers Extended and Set
60'	14	81	---	103,580	*151,200
	15	80	---	94,340	*151,200
	20	75	---	64,930	*127,350
	25	70	---	49,190	*98,300
	30	65	---	39,380	75,330
	35	60	22,150	32,680	59,900
	40	54	19,210	27,800	49,550
	50	41	14,970	21,180	36,530
	60	22	12,030	16,870	27,940
70'	15	82	---	94,140	*151,200
	20	77	---	64,730	*127,080
	25	73	---	48,990	*98,030
	30	69	25,600	39,180	75,230
	35	64	21,820	32,470	59,790
	40	60	18,900	27,600	49,430
	50	50	14,680	20,990	36,400
	60	38	11,760	16,700	28,520
	70	20	9,610	13,670	22,980
80'	17	81	---	79,550	*151,200
	20	79	---	64,510	*126,790
	25	75	---	48,770	*97,750
	30	72	25,250	38,960	75,110
	35	68	21,480	32,260	59,660
	40	64	18,570	27,390	49,280
	50	56	14,370	20,780	36,240
	60	46	11,470	16,490	28,360
	80	19	9,340	13,480	23,080
90'	18	82	---	73,620	*143,360
	20	80	---	64,290	*126,500
	25	77	29,940	48,540	*97,460
	30	74	24,890	38,730	74,990
	35	70	21,130	32,030	59,510
	40	67	18,230	27,160	49,130
	50	60	14,040	20,550	36,070
	60	52	11,150	16,270	28,180
	70	43	9,040	13,270	22,900
	80	33	7,410	11,040	19,110
	90	18	6,120	9,310	16,110
100'	20	81	---	64,060	*126,200
	25	78	29,560	48,310	*97,160
	30	76	24,520	38,500	74,850
	35	73	20,780	31,790	59,350
	40	69	17,890	26,920	48,960
	50	63	13,710	20,320	35,880
	60	57	10,830	16,040	27,990
	70	49	8,720	13,040	22,710
	80	41	7,110	10,820	18,910
	90	31	5,830	9,100	16,060
	100	17	4,780	7,720	13,590

Boom Length	Radius Feet	Boom Angle Degrees	Free Over Side	Free Over Rear	Outriggers Extended and Set
110'	21	82	---	59,960	*118,840
	25	80	29,180	48,070	*96,860
	30	77	24,150	38,260	74,710
	35	74	20,420	31,550	59,190
	40	71	17,530	26,680	48,780
	50	66	13,370	20,080	35,690
	60	60	10,500	15,800	27,800
	70	54	8,400	12,810	22,510
	80	47	6,800	10,590	18,710
	90	39	5,530	8,870	15,860
	110	16	4,490	7,500	13,620
120'	23	81	31,320	53,170	*106,470
	25	80	28,790	47,830	*96,560
	30	78	23,780	38,020	74,570
	35	76	20,050	31,310	59,030
	40	73	17,180	26,440	48,600
	50	68	13,020	19,840	35,500
	60	63	10,170	15,560	27,590
	70	57	8,080	12,570	22,300
	80	51	6,480	10,350	18,500
	90	45	5,210	8,640	15,650
	100	37	4,190	7,270	13,410
	110	29	3,330	6,160	11,620
	120	16	2,600	5,230	9,650
130'	24	82	29,620	50,140	*100,980
	25	81	28,410	47,600	*96,250
	30	79	23,400	37,780	74,420
	35	77	19,690	31,070	58,860
	40	74	16,820	26,200	48,420
	50	70	12,680	19,590	35,300
	60	65	9,830	15,320	27,390
	70	60	7,740	12,320	22,090
	80	55	6,150	10,110	18,290
	90	49	4,890	8,400	15,430
	100	43	3,870	7,040	13,200
	110	36	3,030	5,930	11,410
	120	27	2,310	5,000	9,930
130	15	1,690	4,210	8,060	
140'	26	82	26,890	45,040	*86,130
	30	80	23,030	37,530	74,280
	35	78	19,320	30,820	58,690
	40	76	16,460	25,950	48,240
	50	71	12,330	19,340	35,100
	60	67	9,490	15,070	27,180
	70	62	7,410	12,080	21,870
	80	58	5,820	9,860	18,070
	90	53	4,570	8,150	15,210
	100	47	3,550	6,790	12,980
	110	41	2,710	5,690	11,190
	120	35	2,000	4,760	9,710
	130	26	1,390	3,980	8,480
	140	14	---	3,300	6,640

AMERICAN MODEL 7510 LIFT CRANE RATINGS

Tapered Tip (Continued)

Boom Length	Radius Feet	Boom Angle Degrees	Free Over Side	Free Over Rear	Outriggers Extended and Set
150'	28	81	24,460	40,740	74,040
	30	81	22,650	37,290	71,550
	35	79	18,950	30,580	58,520
	40	77	16,100	25,700	48,060
	50	73	11,980	19,090	34,900
	60	69	9,140	14,820	26,970
	70	64	7,070	11,830	21,650
	80	60	5,490	9,610	17,850
	90	56	4,240	7,900	14,990
	100	51	3,230	6,550	12,750
	110	46	2,390	5,440	10,960
	120	40	1,690	4,520	9,490
	130	33	1,080	3,740	8,260
	140	26	—	3,070	7,210
150	14	—	2,490	5,370	
160'	29	82	23,150	38,700	78,080
	30	81	22,280	37,050	63,060
	35	79	18,590	30,330	58,150
	40	78	15,740	25,460	47,870
	50	74	11,620	18,840	34,700
	60	70	8,800	14,570	26,750
	70	66	6,730	11,570	21,430
	80	62	5,160	9,360	17,620
	90	58	3,910	7,650	14,760
	100	54	2,900	6,300	12,520
	110	49	2,070	5,190	10,730
	120	44	1,370	4,280	9,260
	130	39	—	3,500	8,030
	140	32	—	2,830	6,980
150	25	—	2,250	6,080	
160	14	—	1,740	4,210	
170'	31	81	21,080	35,260	55,000
	35	80	18,220	30,090	51,520
	40	78	15,370	25,210	47,690
	50	75	11,270	18,590	34,500
	60	71	8,450	14,320	26,540
	70	68	6,390	11,320	21,210
	80	64	4,820	9,110	17,400
	90	60	3,580	7,400	14,530
	100	56	2,580	6,050	12,290
	110	52	1,740	4,940	10,500
	120	48	1,040	4,030	9,030
	130	43	—	3,250	7,800
	140	37	—	2,590	6,750
	150	31	—	2,010	5,850
160	24	—	1,500	5,070	
170	13	—	1,050	3,150	

Boom Length	Radius Feet	Boom Angle Degrees	Free Over Side	Free Over Rear	Outriggers Extended and Set
180'	32	82	19,930	33,590	47,440
	35	81	17,850	29,840	45,910
	40	79	15,010	24,960	42,530
	50	76	10,920	18,340	34,290
	60	72	8,100	14,060	26,320
	70	69	6,050	11,070	20,990
	80	66	4,480	8,850	17,170
	90	62	3,250	7,150	14,300
	100	58	2,240	5,790	12,060
	110	54	1,420	4,690	10,270
	120	50	—	3,770	8,790
	130	46	—	3,000	7,560
	140	41	—	2,340	6,520
	150	36	—	1,760	5,620
160	31	—	1,260	4,840	
170	23	—	—	4,110	
190'	34	81	18,140	30,760	41,800
	35	81	17,480	29,590	41,110
	40	80	14,650	24,710	38,020
	50	77	10,560	18,090	33,110
	60	73	7,760	13,810	26,110
	70	70	5,710	10,820	20,770
	80	67	4,140	8,600	16,950
	90	64	2,910	6,890	14,070
	100	60	1,910	5,540	11,830
	110	57	1,090	4,440	10,030
	120	53	—	3,520	8,560
	130	49	—	2,750	7,330
	140	45	—	2,090	6,280
	150	40	—	1,510	5,390
160	35	—	1,010	4,600	
170	30	—	—	3,920	
200'	35	82	17,110	29,340	36,360
	40	80	14,290	24,460	34,120
	50	77	10,210	17,840	29,620
	60	74	7,410	13,560	25,890
	70	71	5,360	10,560	20,550
	80	68	3,800	8,340	16,720
	90	65	2,570	6,640	13,840
	100	62	1,580	5,280	11,600
	110	59	—	4,180	9,800
	120	55	—	3,270	8,320
	130	51	—	2,490	7,090
	140	48	—	1,830	6,050
	150	44	—	1,260	5,150
	160	39	—	—	4,370
170	34	—	—	3,680	

Load ratings do not exceed 85% of tipping with crane standing level on firm, uniformly supporting surface. Safe loads depend on ground conditions, boom length, radius of operation, condition and inflation (100 PSI) of tires, and proper handling, all of which must be taken into consideration by user. Ratings marked (*) are based on strength, not stability. "Radius in feet" is the horizontal distance at ground level from center pin to a vertical line through the center of gravity of the suspended load. Blocks, slings, buckets and other load-carrying devices are considered part of the load.

Retractable A-frame must be in fully raised position for above ratings. Free ratings do not exceed maximum permissible tire load. Free ratings are omitted where, without load, backward stability is less than industry standard.

For loads up to 46,500 lbs use 2-part maximum reeving without hanger block. Reduce ratings 800 lbs when using optional double sheave hanger block (for up to 6-part line).

Standard equipped crane with "K-F-L" counterweight and outriggers extended and set will self erect 200 ft main boom plus 50 ft No 9 jib or 60 ft No 9HL jib.

Jib Ratings

JIB OFFSET "A"

MAXIMUM JIB RATING IN POUNDS

NO. 9 JIB RATINGS				
	20 ft Jib	30 ft Jib	40 ft Jib	50 ft Jib
0 to 6 ft	18,000	18,000	14,500	10,500
9 ft	18,000	17,300	14,100	10,250
12 ft	18,000	15,300	12,400	10,000
15 ft	—	13,500	10,750	8,800
18 ft	—	—	10,000	8,150
21 ft	—	—	—	7,750
Effective Jib Weight at Boom Point	1,550	2,100	2,800	3,600

No 9 Jib ratings are based on 80 ft minimum boom length

NO. 9HL JIB RATINGS			
	40 ft Jib	50 ft Jib	60 ft Jib
0 to 8 ft	19,000	17,000	14,500
12 ft	16,600	14,800	12,600
16 ft	14,400	12,800	11,600
20 ft	12,000	11,000	10,300
24 ft	—	—	9,000
28 ft	—	—	8,000
Effective Jib Weight at Boom Point	1,850	2,350	2,750

No 9HL Jib ratings are based on 120 ft minimum boom length

Jib ratings are based on the minimum boom length specified above. For ratings on shorter booms consult factory. The jib load rating is the lesser of: (a) the maximum jib rating shown above or (b) the main boom rating at the jib working radius reduced by 600# for the No 9 jib or 200# for the No 9HL jib. The weight of all suspended load carrying devices including main boom block must be deducted from jib ratings.

The main boom rating with jib in place must be reduced by the effective jib weight, the weight of main fall blocks and slings, and twice the weight of jib tackle.

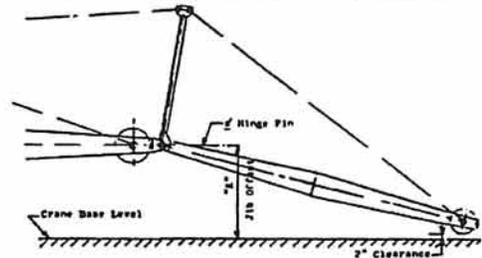

7510 GENERAL SPECIFICATIONS

UPPER MACHINERY:

POWER:

Standard: General Motors Model 6-71-N diesel engine with three stage hydraulic torque converter; six cylinder, 4¼" bore, 5" stroke, 426 cu in displacement, rated 208 HP at 2100 RPM converter input, 12 volt electric starting

Alternate Engines with Three Stage Hydraulic Torque Converter:

Cummins Model N-743-P diesel engine, six cylinder, 5½" bore, 6" stroke, 743 cu in displacement, rated 187 HP at 2100 RPM converter input, 24 volt electric starting

Caterpillar Model D-333C-T diesel engine, 6 cylinder, turbocharged, 4¾" bore, 6" stroke, 638 cu in displacement, rated 200 HP at 2050 RPM converter input, 24 volt electric starting

NOTE: Power ratings are nominal and may vary ±5%

FUEL TANK: 117 gallons capacity

POWER TRANSMISSION: Multiple roller chain transmits power from engine to operating machinery; completely enclosed, running in oil for long trouble-free service

ROTATING MACHINERY BASE: Tapered deep girder, electric welded steel plate construction with integral walkways; deep rigid sections with bored and

drilled holes located by jigs and fixtures to keep machinery in alignment under most severe operating conditions and assure fit of replacement parts

COUNTERWEIGHT: K-F-L, 31,000 lbs made up of basic hollow casting with corner and center inserts

ROLLER PATH AND BULLGEAR: Roller path and bullgear are a single unit casting, internal tooth bullgear; outer surface of the bullgear has double tapered roller paths accurately machined to roller contour, welded to chassis of carrier with suitable reinforcement and bracing

CENTER PIVOT TUBE: Center pivot tube cast integral with roller path and bullgear, pressure grease lubricated bronze pivot bushings in rotating machinery base; horizontal loads only — no uplift

LOAD AND HOOK ROLLERS: Large tapered load rollers transmit downward loads to machined upper roller path on carrier; tapered hook rollers transmit uplift loads to lower path on carrier; two sets double equalizing load rollers and two single hook rollers in front; two sets double equalizing hook rollers and two single load rollers in rear; all rollers mounted on anti-friction bearings; hook rollers easily adjustable by eccentric shaft take-up

DRIVE SHAFT ASSEMBLY: Independent primary drive shaft consists of forged alloy steel shaft with cut steel pinion splined to shaft; roller chain sprocket is

7510 GENERAL SPECIFICATIONS (Cont.)

splined to other end of shaft; shaft mounted in pressure grease lubricated anti-friction bearings. This shaft assembly has a single purpose of speed reduction and is not compromised by mounting clutches for other functions.

SWING ASSEMBLY: Alloy steel horizontal reversing shaft is mounted in anti-friction bearings; reversing bevel pinions are mounted on independent tapered roller bearings in rigid housing so that shaft is not subjected to bending loads; hardened alloy steel bevel and spur gears have accurately cut teeth and run in oil bath for maximum service life; air controlled, tandem band, internal swing clutches have extra thick moulded linings for long service life and stable operation; the air control system consists of a graduated air valve with ample hand lever travel to assure close control.

Vertical reverse shaft is heat-treated alloy steel, pressed into machinery base casting; integral cast alloy steel bevel gear and spur pinion mounted on anti-friction bearings; oil lubricated gearing; accurate, permanent gear alignment with long wear due to anti-friction mounting of bevel pinions and gear in rigid castings forming the machinery case.

Vertical swing shaft is heat-treated alloy steel mounted on bronze bushings in machinery base cover casting and gear case lower casting; forged alloy steel swing pinion; alloy cast iron brake wheel mounted on accurately cut splines; cast steel horizontal spur gear, running in oil; air-controlled swing brake is spring set, air released, controlled by a graduated air valve; swing brake is also set by side motion of the swing lever.

HYDROSTATIC SWING (Optional): Variable displacement piston pump is direct driven off the front of the engine; constant displacement piston motor is geared to swing turntable through 3-spur reduction; closed hydraulic circuit between pump and motor; operator has direct control of the pressure exerted on the motor for swinging in either direction; swing motion is substantially independent of engine speed.

MAIN DRUM ASSEMBLY: Twin alloy cast ductile iron drums with integral brake and clutch surfaces are mounted on anti-friction bearings; drums skeleton type with split cast steel laggings bolted in place; alloy steel drum shaft mounted in anti-friction bearings in machinery base; clutch spiders splined to drum shaft; air controlled clutches with tandem external contracting bands with thick moulded linings; smooth operation assured by highly responsive variable pressure air controls; large external contracting band drum brakes with extra thick moulded linings; brake foot pedal operated from operator's position; brake shafts and pins mounted on anti-friction bearings for responsive operation with minimum effort; brake and clutch surfaces stress relieved for smooth operation without scoring; cooling fins on brake ring assure maximum dissipation of heat.

A spring set, air released brake mechanism, controlled from the operator's lever stand, holds the drum from rotating in the lowering direction and is capable of holding a maximum load indefinitely in the event that there is a loss of air during crane operations; this is standard equipment on all machines furnished with crane boom.

CONTROLLED LOAD LOWERING: The controlled load lowering shaft is mounted behind and above the main drum shaft; shaft is alloy steel mounted in anti-friction bearings in the standard A-frame; roller chain

sprocket is bolted to a special drum lagging; a mating drive sprocket is provided on the load lowering shaft; clutch is internal expanding band type. Controlled load lowering can be provided for either the right hand or left hand drum, but not both simultaneously; the large driven sprocket is bolted to the special lagging and can be bolted to either right or left lagging as desired.

Loads are lowered through the chain drive to the lowering shaft, then through the lowering clutch to the gear train and back to the engine where they are resisted by the over-running friction torque of the engine and torque converter. A single air valve controls both hoisting and lowering. The foot brake stops the load.

The controlled load lowering is completely independent of all other operations.

NOTE: Three stage torque converter must be used with controlled load lowering for required gear ratios.

THIRD DRUM (Optional): Forward and below main drum, heat-treated alloy steel shaft splined for clutch spider and third drum; shaft mounted on anti-friction bearings in integral pillow block casting; clutch gear mounted on anti-friction bearings; air-controlled tandem external contracting clutch bands; moulded liners; third drum 10" dia x 15" long, 15,000 lbs SLP at 185 FPM; latched foot brake at operator's position.

CRANE BOOM: A special lightweight, pin connected deep section crane boom is furnished with chords of tubular T-1 steel and with tubular lattice; boom is 59" cross section and can be extended to 200 ft plus jib; the basic inner section is 20 ft long; the tapered intermediate section can be fitted either with a 5-sheave pin connected hammerhead or with a 20 ft 2-sheave pin connected (tapered tip) outer section; minimum length hammerhead boom is 40 feet; minimum tapered tip boom is 60 feet; tapered tip boom includes two sheave hanger block, which with lower hook block permits reeving up to six part line; hammerhead tip boom permits reeving up to nine part line; hammerhead tip is required for loads requiring less than 60 foot boom, and for maximum crane rating of 100 tons (on 40 foot boom); center sections with matching pendants available in 10 ft, 20 ft and 40 ft lengths; no belly lines required for maximum length booms; jib can be fitted to either hammerhead or tapered tip.

JIBS: No. 9 jib is 20 ft, 2-piece with alloy steel chord angles and tubular lattice; 20" AFB sheave is grooved for 7/8" rope for single part whipline; 10 ft center sections with matching pendants are available to extend total jib length to 30 ft, 40 ft or 50 ft length.

No 9HL jib is 40 ft, 2-piece with T-1 tubular alloy steel chords and tubular lattice; 20 ft inner; 20 ft. outer; 24" AFB aluminum sheave is grooved for 7/8" or 1" rope; 10 ft and 20 ft center sections with matching pendants are available to extend total length to 50 ft or 60 ft.

Jib back stay ears are located on the 20 ft outer base section; jib back stay length must equal or exceed jib length, for longer jibs the back stay line is attached at boom inner section or optional ears on center boom section.

SAFETY BOOM STOPS: Telescoping pipe safety boom stops for any length boom prevent overhoisting and backward boom motion due to failure of hoisting line or

7510 GENERAL SPECIFICATIONS (Cont.)

hoisting tackle Standard on all machines with crane boom

BOOM HOIST SAFETY SHUT-OFF: Prevents the operator from over hoisting the boom, located at the bottom of the boom and actuated when the boom reaches a predetermined angle; when activated this valve cuts off the air supply to boom hoist clutch and sets the boom hoist brake Standard on all machines with crane boom

BOOM HOIST: Bronze bushed cast steel boom hoist drum mounted on stationary shaft in machinery base; powered through gear train from engine through swing shaft to boom hoist shaft; single lever graduated air valve controls both raising and lowering; cut tooth spur gear is mounted on anti-friction bearings with alloy cast iron clutch ring keyed to gear hub; clutch spider is splined to clutch shaft; air controlled clutch is external contracting band; clutch shaft is mounted on bronze bushings in machinery base; spring set, air released contracting band brake; spring set, air released locking pawl holds boom during operation or when machine is idle

CONTROLLED BOOM LOWERING: Boom lowering speed limited by speed of engine; rapid, safe boom handling; slower boom lowering by reduced engine speed; overrunning sprag clutch mechanism mounted on independent shaft engages positively and smoothly; disconnect provided for reversed gear operations; shifter interlocked with boom brake to prevent "live boom"

RETRACTABLE A-FRAME is raised or lowered by means of bail rigging with no special equipment required; standard on all machines, complete counterweight removed easily and quickly, without assistance, through use of retractable A-frame and counterweight removal attachment; two alloy cast steel arms are pivoted from rear of machinery deck; alloy steel hooks suspend the counterweight from these arms and machined cast steel latches secure the arms; counterweight is further secured by two over-center locking arms; no bolts are employed; attaching counterweight is an equally simple procedure

CAB: Fully enclosed 10'6" wide steel; all safety glass windows mounted in rubber; removable windows in operator's cab; sliding doors on sides and rear; hinged door on operator's cab roof; ladder to roof at left front; operator located at right hand forward corner to provide unobstructed visibility.

ATTACHMENTS:

DRAGLINE ATTACHMENT: Includes full revolving fairlead, dirt guard under dragline drum, drum lagging, 7/8" hoist line and 1 1/8" dragline for applicable boom length

CLAMSHELL ATTACHMENT: For clam or grapple work includes Rud-O-Matic tagline winder mounted in boom, drum lagging, 7/8" holding line and 7/8" closing line for applicable boom length

MAGNET ARRANGEMENT: 21 KW constant voltage magnet generator is belt driven from main engine, eliminating extra fuel costs and maintenance of second engine; voltage regulator holds voltage constant under all operating conditions; magnet controller mounted on operator's cab wall; pushbuttons mounted in operating levers so operator need not release control lever while operating magnet

Over-excitation arrangement increases magnet pick-up capacity up to 20%, increasing daily output; when magnet is dropped on pile of material the operator pushes "LIFT" button on hoist lever which raises generator voltage to 275, materially increasing magnet pick-up capacity; when free from pile the button is released and voltage drops to 200, which is ample to hold the load, to release the load the operator pushes the "DROP" button on the swing lever

Included with magnet arrangement are Gleason cable reel, Rud-O-Matic tagline winder, single sheave crane block with bronze bushed sheave and two-part magnet hoist line

GUY DERRICK ATTACHMENT: Lifting capacity is increased to 280,000 lbs Special mast boom and derrick boom component parts include a modified derrick boom inner to be used as the mast inner, a mast tip with guy cap, derrick boom inner, derrick boom intermediate section, and a special 8 sheave derrick boom outer section Center boom sections and pendants are interchangeable with derrick mast and boom sections A special auxiliary third drum is used which has a larger rope capacity, and the 140 ton load block is furnished

GENERAL

CONTROLS: Graduated air controls, pioneered by AMERICAN, put "feel" at every operator's fingertips, insure higher production, more accurate control

MATERIALS: Gears and pinions are heat-treated alloy or high carbon steel, cut teeth on all gears except rotating ring gear which has accurately moulded teeth

Involute splines are used throughout machine for maximum tooth strength through minimum diameter where needed; self centering; equalized bearing and stress among all teeth; smooth tooth surface; easy interchangeability of parts

Anti-friction bearings are used on all main or high speed shafts and wherever practical to provide friction-free, smooth operation with minimum maintenance

LUBRICATION: All anti-friction bearings and bronze bushings requiring short period lubrication are provided with pressure grease fittings; swing deck gears are provided with oil bath lubrication; drum gear train and the swing bullgear are arranged for grease lubrication

CARRIER: For carrier details and general dimensions see separate specification

PERFORMANCE:

SWING SPEED 3 RPM

SINGLE LINE SPEED:

Crane Hoist	165 FPM
Dragline	140 FPM
Magnet	200 FPM
Third Drum	185 FPM

SINGLE LINE PULL (with standard engine):

Crane Hoist	27,000 lbs	SLP
Dragline	32,000 lbs	SLP
Magnet	22,000 lbs	SLP
Third Drum	15,000 lbs	SLP

NOTE: In accordance with varying material situations and the Company's policy of constant product improvement these specifications subject to change without notice and without incurring responsibility to units previously sold

Boom Angle Diagram

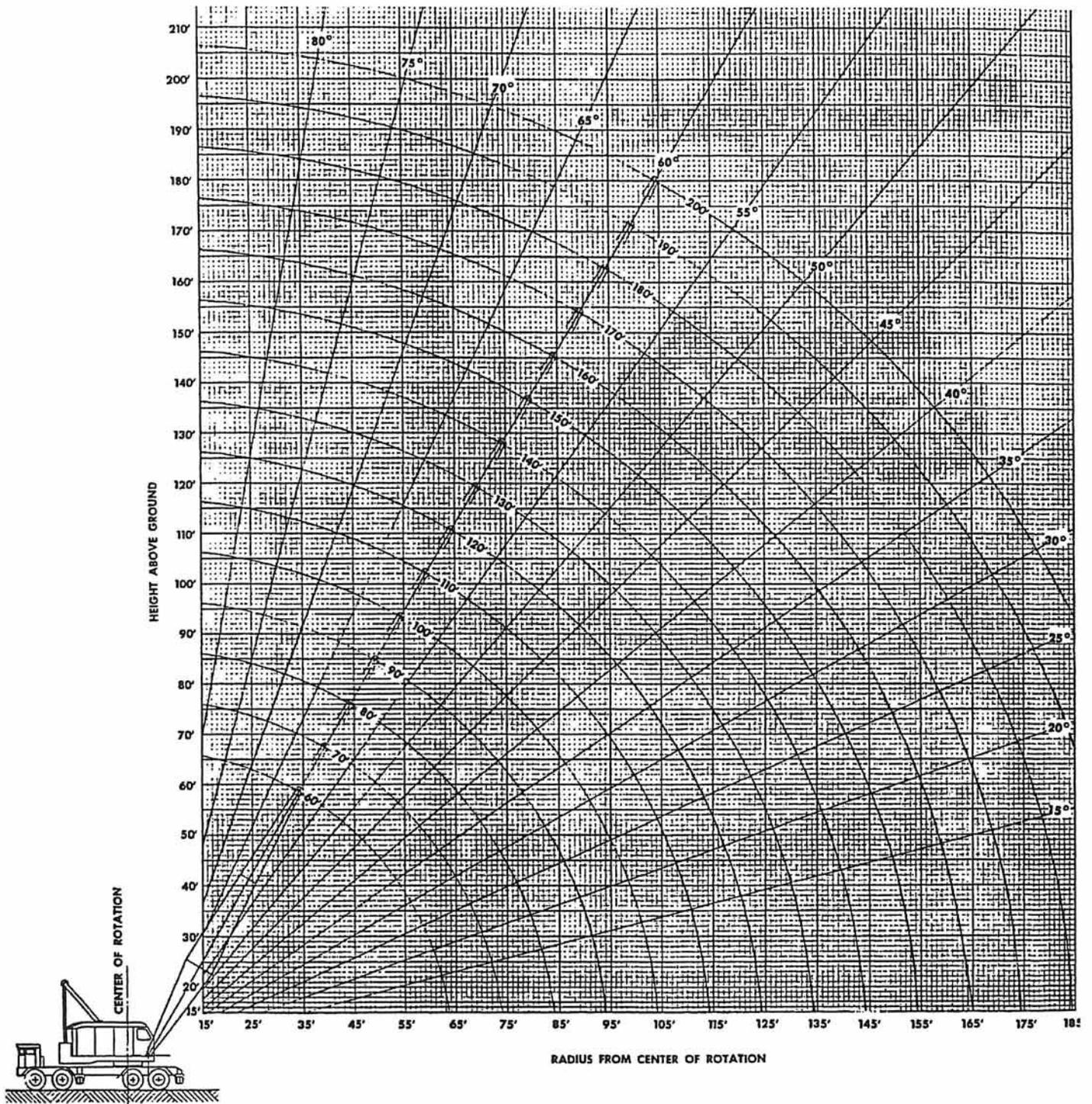

AMERICAN MODEL 7510 TRUCK CRANE

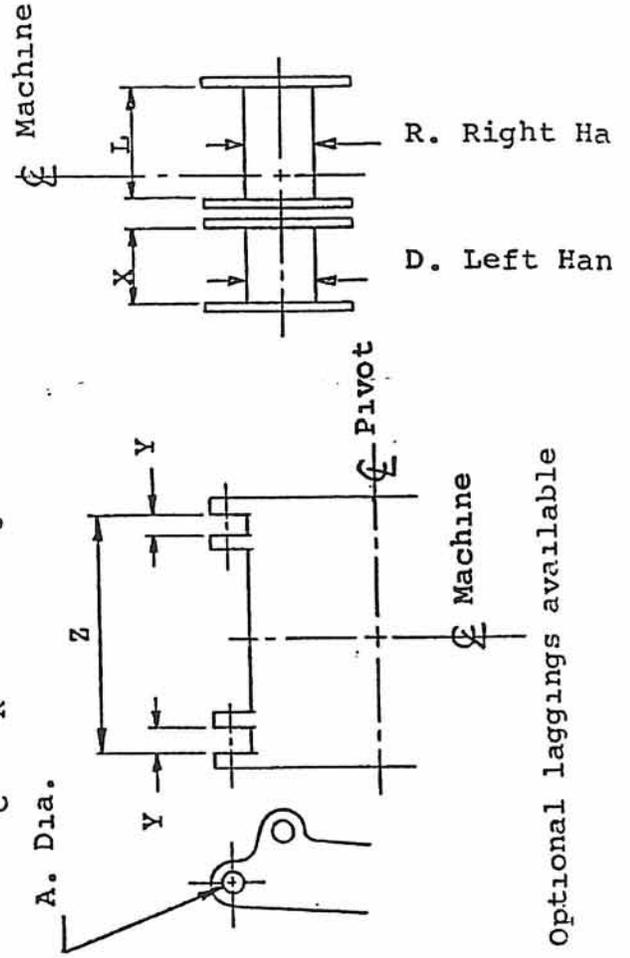
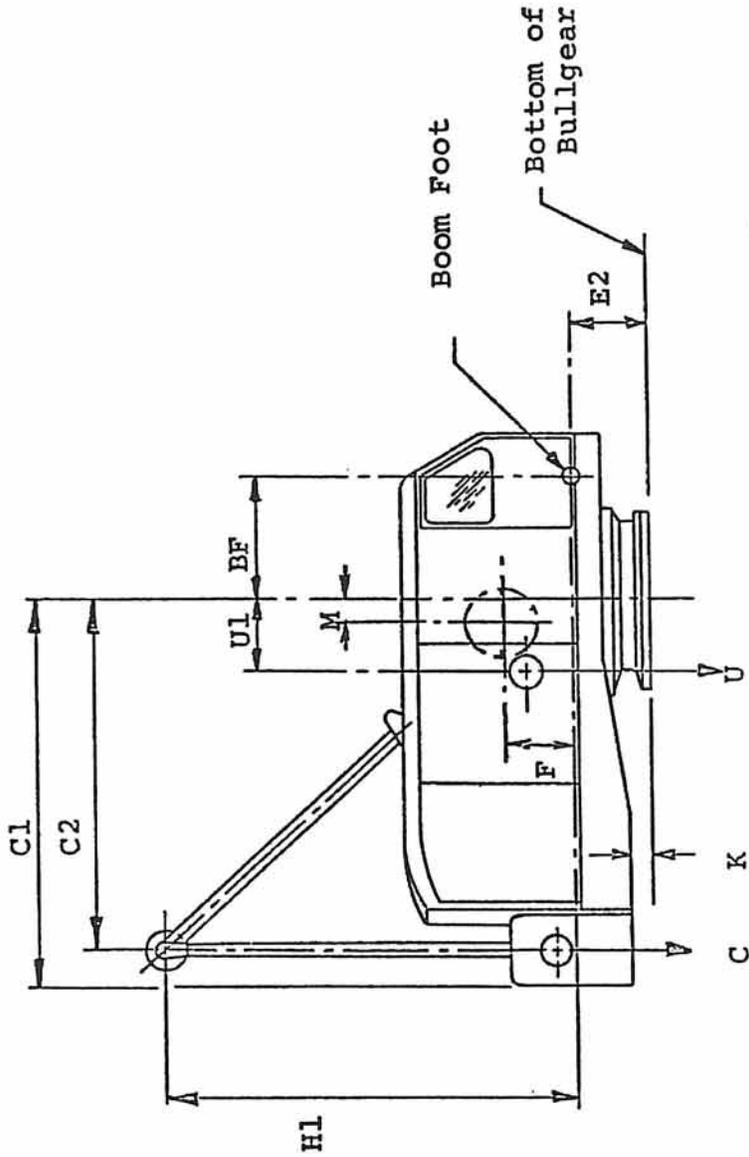

* Optional laggings available

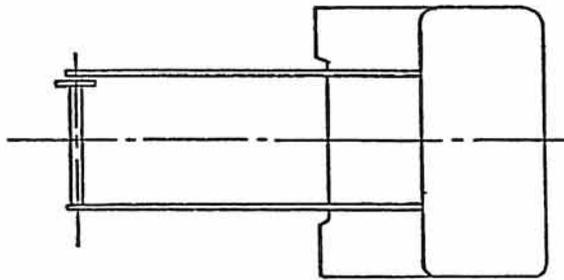

A.	3.255"	Y.	4"
C.	3.265 Dia.	Z.	5.0'
D.	31,000#	BF.	4.125'
F.	21-1/2" *	C1	14.125'
L.	28.382"	C2	12.7'
M.	17.5"	E2	2.0156'
R.	15.375"	H1	14.396'
U.	21-1/2"	UL	3.24'
X.	47,070#	K	.4896'
	12 5"		

TRUCK CRANE CARRIER

MODEL: 7510
 MAKE: AMERICAN
 TYPE: 8 x 4

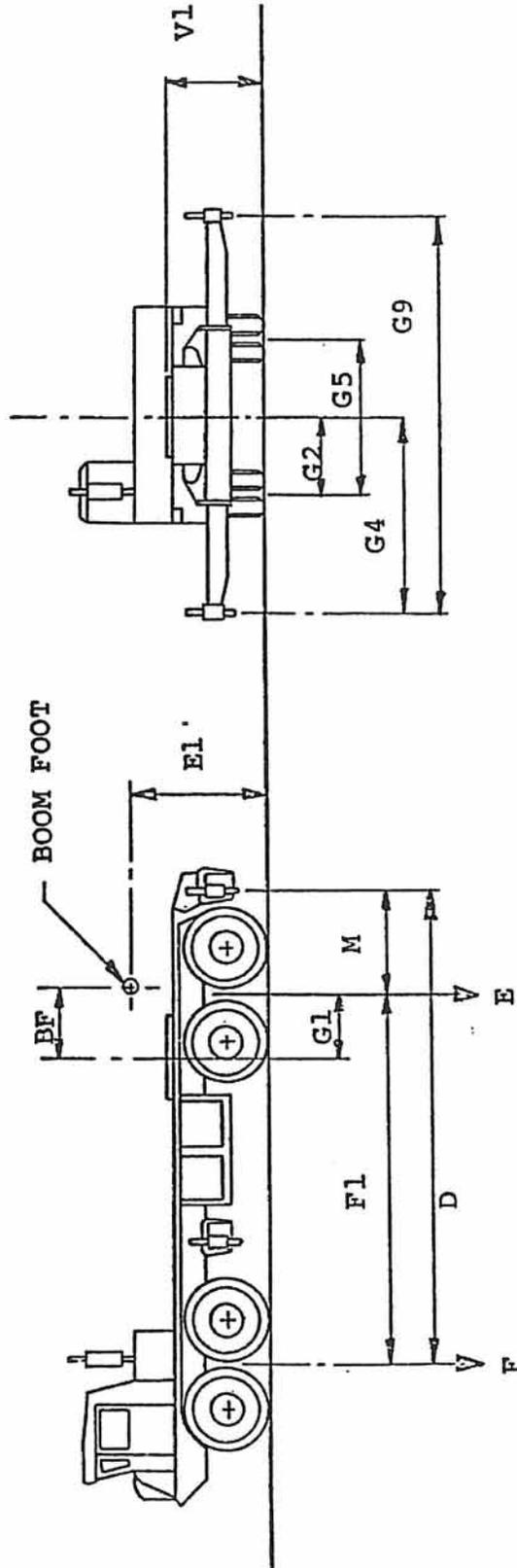

BF -	<u>4.125</u>	FT.	G1 -	<u>3.5</u>	FT.
E1 -	<u>6.77</u>	FT.	G2 -	<u>3.75</u>	FT.
E -	<u>37.6</u>	KIPS	G4 -	<u>9.65</u>	FT.
D -	<u>20.0</u>	FT.	G5 -	<u>7.5</u>	FT.
F1 -	<u>19.85</u>	FT.	G9 -	<u>19.30</u>	FT.
M -	<u>6.4</u>	FT.	V1 -	<u>4.750</u>	FT.
F -	<u>23.8</u>	KIPS			

132 KIPS MAXIMUM ALLOWABLE TIRE LOAD OVER SIDE.

210 KIPS MAXIMUM ALLOWABLE TIRE LOAD OVER END.

WEIGHT AND CENTER OF GRAVITY

SA-70-12-24-WB
 AMERICAN HOIST & DERRICK CO
 SAINT PAUL, MINNESOTA

59" HEAVY DUTY TUBULAR BOOM

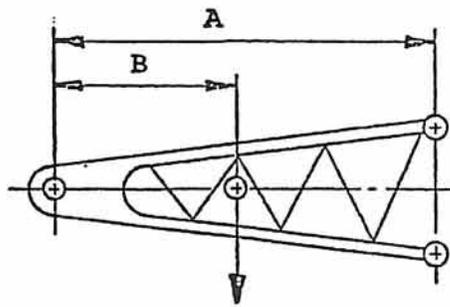

C
 INNER

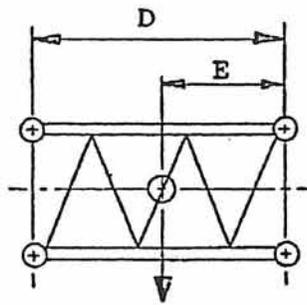

F
 CENTER

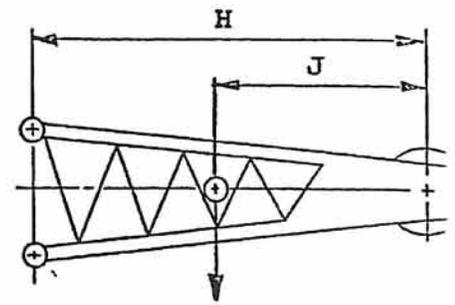

K
 OUTER

20'-0" Inner

20'-0" Outer Base

20'-0" Taper Tip

10'-0" Center

20'-0" Center

40'-0" Center

Hammerhead weighs 2,150#

A = 20'-0", B = 8'-2", C = 2,200#

D = 19'-11-3/4", E = 11'-0", F = 980#

H = 20'-0", J = 11'-0", K = 1,570#

D = 10'-0", E = 5'-0", F = 604#

D = 20'-0", E = 10'-0", F = 1,208#

D = 40'-0", E = 20'-0", F = 2,318#