

GRT8120

Product guide

ASME B30.5
Imperial 85%



Features

- 120 t (120 USt) capacity
- 11,3 m - 60 m (37.2 ft - 197 ft) seven-section MEGAFORM™ boom
- 10,5 m - 17,6 m (34.5 ft - 57.6 ft) manual or hydraulic bi-fold lattice swingaway extension with offsets up to 45°
- Crane Control System (CCS)
- New wider full vision cab with 20° cab tilt
- MAXbase variable outrigger positioning system

GROVE GRT8120

The GRT8120 was designed after gathering feedback from crane owners and operators to ensure that it is loaded with the features and reliability you demand.

Features

> Unmatched reach with compact carrier

Class-leading lifting performance is enhanced by the 11,3 m to 60 m (37.2 ft to 197 ft) seven-section MEGAFORM™ boom with TWIN-LOCK™ boom pinning system. This amount of main boom length is typically reserved for rough terrain cranes in the 135 t - 150 t (150 US t - 165 US t) class, however when combined with a compact carrier with dimensions of cranes in the 70 t - 90 t (80 US t - 100 US t) class, make the GRT8120 a truly versatile crane that should be in every crane owners fleet. Boosting overall reach is the 17,6 m (57.6 ft) manual or hydraulic swingaway jib for a maximum tip height of 80,8 m (265 ft).

> MAXbase variable outrigger positioning

MAXbase provides increased versatility on the jobsite by allowing asymmetrical outrigger spans. This makes it easier to work in congested jobsites with obstructions, and allows for increased capacities when comparing to the standard 360° load charts.

> New wider full vision cab

The new wider full vision cab was designed with operator comfort, visibility and productivity in mind. Additional width, redesigned armrests and 20° cab tilt maximize the operator experience. Standard features include tilt/telescoping steering wheel, USB charging port, electronic seat adjustments, high-output heating and air conditioning system, large pivoting cup holder, windshield sun visor, added storage behind the seat, and three camera package. Additional optional equipment includes radio with Bluetooth and heated seat.

> Backing up our promise

Our new GRT line of Rough Terrain cranes have been designed from the ground up to provide class-leading specifications, and have undergone extensive testing to ensure they provide industry-leading quality and reliability. We stand behind our new line of GRT cranes, and we are willing to prove it. With new three, four or five-year extended warranty programs as well as a new two-year standard warranty, our GRT line of cranes are built to be GROVE. REAL. TOUGH.

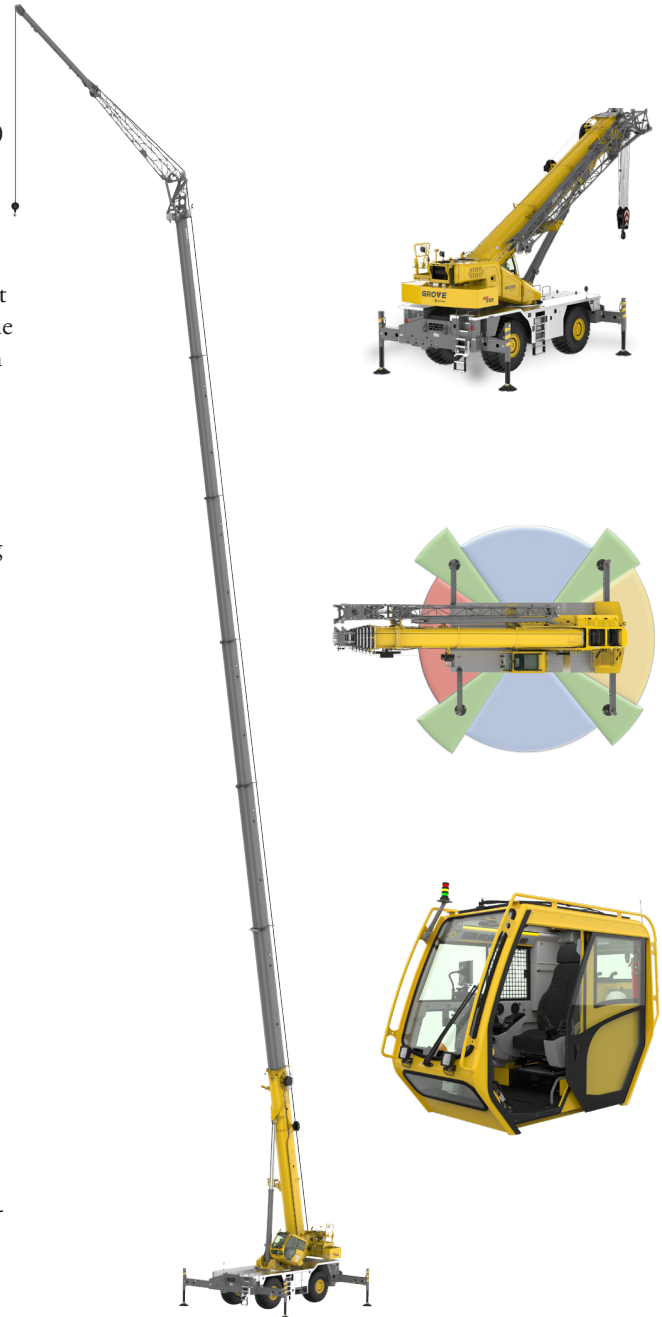

**THE ONLY FIVE-YEAR
WARRANTY PROGRAM
AVAILABLE IN THE INDUSTRY**

GRT8120 benefits

- > Class-leading boom length and capacities maximize utilization.
- > Compact dimensions with self-rigging counterweight allow for efficient and easy transportation to the job.
- > Wireless rigging remote enables fast and convenient setup.
- > Flat aluminum decking, additional storage compartments and a full LED lighting package with new side-mounted carrier lights improve access and jobsite set up.
- > MAXbase variable outrigger positioning system - Increased lift capacities and easy access to any jobsite.
- > TWIN-LOCK™ boom pinning system maximizes capacities by reducing weight inside the extended boom.
- > Boom Configurator mode increases efficiency and simplifies telescoping operation.
- > Manual or hydraulic bi-fold swingaway with offset capability to 45° increases ability to reach over obstacles and increases jobsite versatility.
- > Innovative smart-sensing outrigger monitoring system offers reliable accuracy.
- > ECO mode supports intelligent power management and decreased fuel consumption.
- > New wider cab with 20° cab tilt and high-output heating and air conditioning system maximizes operator comfort.
- > Four modes of steering increase jobsite maneuverability and make crane positioning easier.



Manitowoc Crane Care when you need it.

The assurance of the world's most advanced crane service and support to get you back to work fast.



Manitowoc Finance helps you get right to work generating profits for your business.

Financial tools that help you capitalize on opportunity with solutions that fit your needs.

Contents

- Dimensions 5
- Weights 6
- Working range - Main boom and bi-fold extension7
- Load chart - Main boom 8
- Load chart - MAXbase 20° over outriggers (*Provisional*) 9
- Load chart -Manual bi-fold extension.....10
- Load chart - Hydraulic bi-fold extension 12
- Load chart - Pick and carry 14
- Load chart - Stationary 15
- Rigging charts 16
- Load handling17
- Specifications..... 18
- Symbols glossary 20

Dimensions

Tire size: 29.5 x 25

A	B	C	D	E	F	G	A	B	C	D	E	F	G
17526 mm (690")	16713 mm (658")	14630 mm (576")	13970 mm (550")	13564 mm (534")	11278 mm (444")	9957 mm (392")	11938 mm (470")	11227 mm (442")	8661 mm (341")	7798 mm (307")	7493 mm (295")	4826 mm (190")	4521 mm (178")
Two-wheel steer							Four-wheel steer						

Dimensions in mm (in) unless otherwise specified.

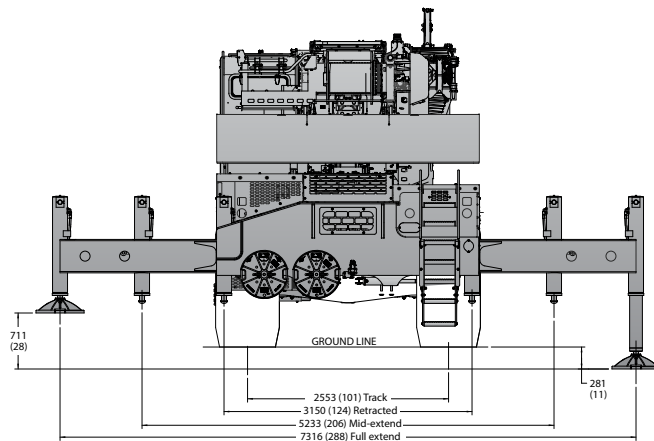
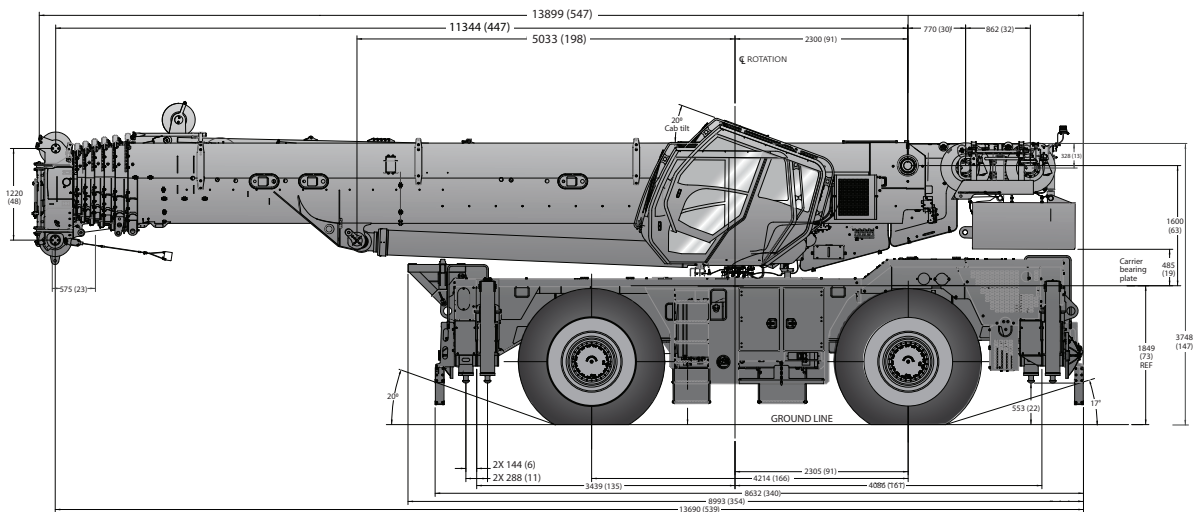
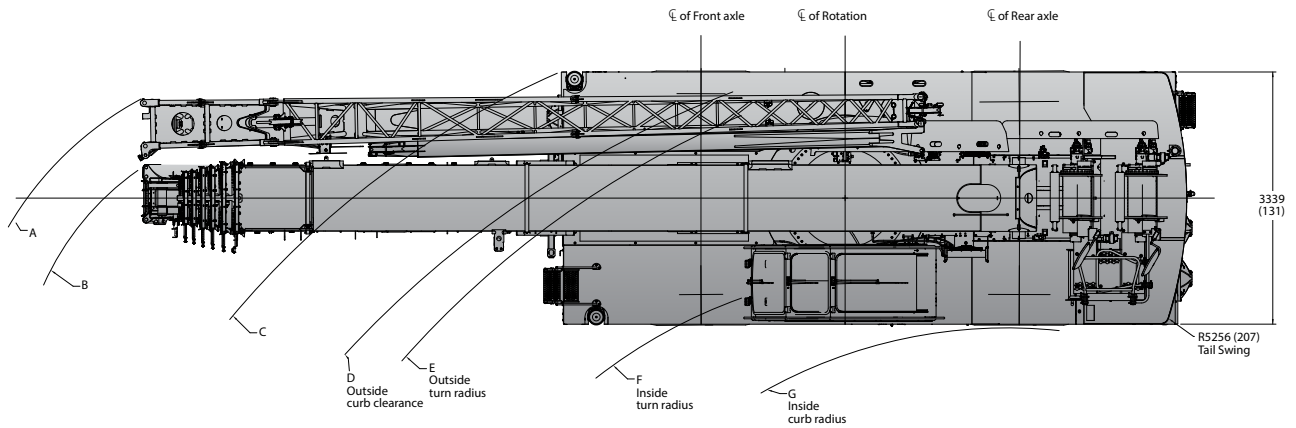

Weights

Weights						
	Gross		Axle 1		Axle 2	
	kg	lb	kg	lb	kg	lb
Basic crane with Cummins T4F engine, 60 m (197 ft) main boom, main and auxiliary hoist with wire rope, 17.6 m (57.6 ft) manually offset bi-fold swingaway, 75 t (83 USt) hookblock, 11 t (12 USt) overhaul weight, auxiliary boom nose and 13 245 kg (29,200 lbs) counterweight	59,017	130,111	29,018	63,974	29,999	66,137
Remove 13 245 kg (29,200 lb) counterweight	-13,245	-29,200	4,907	10,818	-18,152	-40,018
crane weight	45,772	100,911	33,925	74,792	11,847	26,119
Remove 17.6 m (57.6 ft) manually offset bi-fold swingaway	-1,488	-3,280	-2,505	-5,523	1,017	2,243
crane weight	44,285	97,631	31,420	69,269	12,865	28,362
Remove Auxiliary boom nose	-88	-194	-245	-541	157	347
crane weight	44,197	97,437	31,174	68,728	13,022	28,709
Remove 11 t (12 USt) overhaul weight	-294	-648	-471	-1,038	177	390
crane weight	43,903	96,789	30,704	67,690	13,199	29,099
Remove 75 t (83 USt) hookblock	-1,070	-2,359	-1,715	-3,780	645	1,421
crane weight	42,833	94,430	28,989	63,910	13,844	30,520
Basic crane as noted above: Substitute 10.5 m - 17.6 m (34.5 ft - 57.6 ft) hydraulically offset bi-fold swingaway and hydraulic hose reel ILO standard manual bi-fold swingaway	238	525	400	882	-162	-357
crane weight	59,255	130,636	29,418	64,856	29,837	65,780

*THIS CHART IS ONLY A GUIDE AND SHOULD NOT BE USED TO OPERATE THE CRANE.
The individual crane's load chart, operating instructions and other instructional plates must be read and understood prior to operating the crane*

Working range

Working range diagram with bi-fold extension

(Boom deflection not shown)

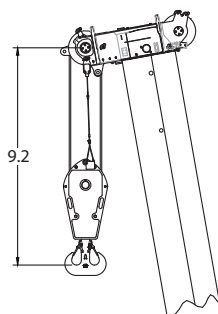
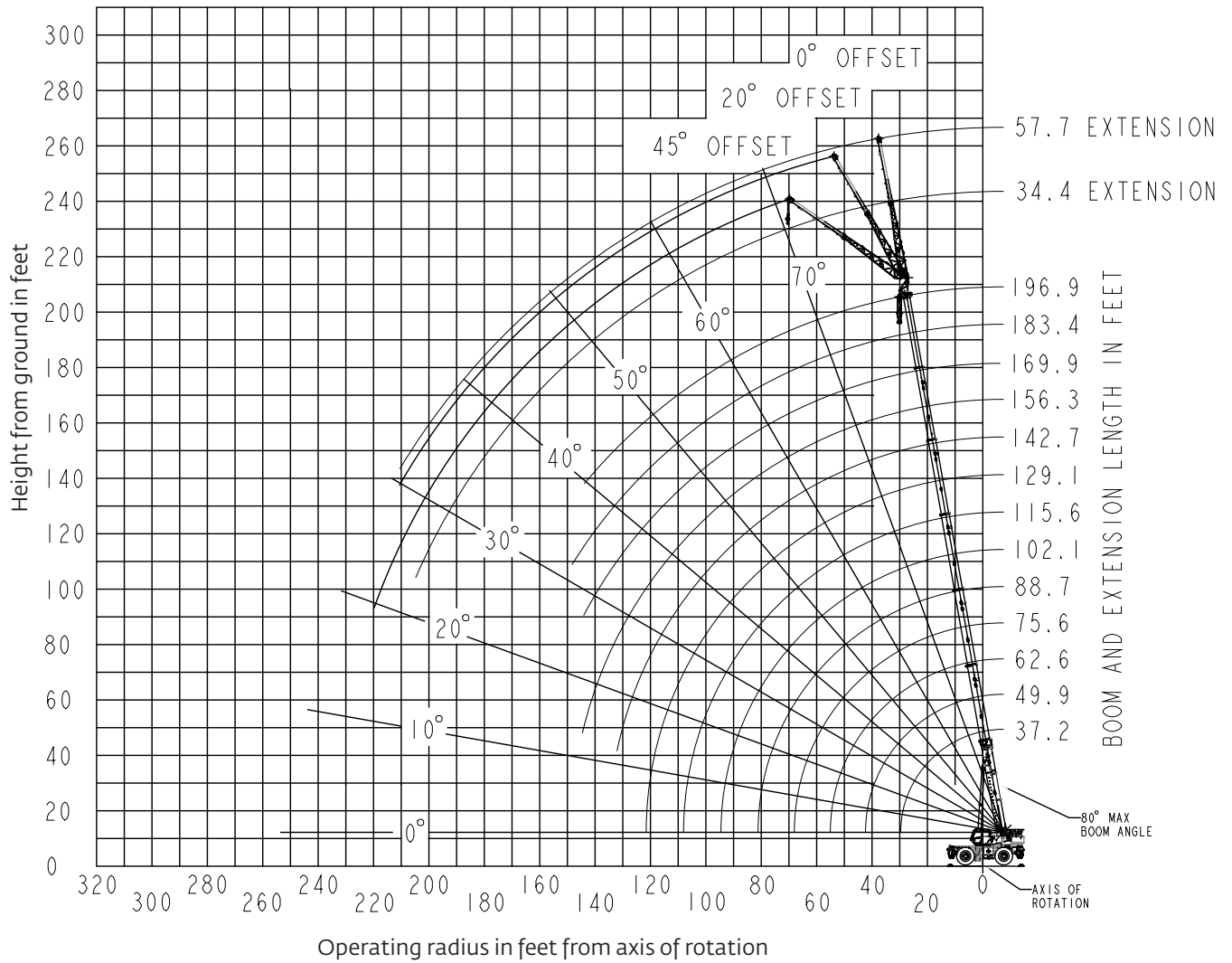

Dimension shown is for the largest Grove furnished hookblock with anti-two block activated.

*THIS CHART IS ONLY A GUIDE AND SHOULD NOT BE USED TO OPERATE THE CRANE.
The individual crane's load chart, operating instructions and other instructional plates must be read and understood prior to operating the crane*

Load chart

Main boom



37.2 ft - 197 ft



29,200 lb



100%



360°



Pounds

Radius in feet	Main boom length in feet												
	37.2	49.9 - 50.8	60.5 - 64.4	73.6 - 78	84.5 - 91.3	98 - 104.4	109.3 - 117	122.9 - 137.7	147.9 - 154.1	156.3 - 169.9	183.4 - 184.1	194.7 - 196.9	
8	240,000*	—	—	—	—	—	—	—	—	—	—	—	—
10	176,500	177,500	160,000	—	—	—	—	—	—	—	—	—	—
12	158,000	159,000	145,000	125,000	—	—	—	—	—	—	—	—	—
15	134,000	135,000	129,500	114,000	97,700	—	—	—	—	—	—	—	—
20	101,000	103,000	102,000	95,700	85,750	80,250	—	—	—	—	—	—	—
25	79,950	82,150	81,450	81,400	75,600	69,250	65,350	53,500	—	—	—	—	—
30	—	65,000	66,050	65,900	64,800	62,800	58,700	53,500	36,600	—	—	—	—
35	—	53,300	53,550	53,450	55,000	54,850	52,950	48,950	36,600	29,700	—	—	—
40	—	43,250	43,700	44,850	44,100	45,500	44,200	43,050	36,600	29,350	21,200	—	—
45	—	—	36,750	36,750	37,200	37,350	36,100	35,000	35,550	29,350	21,200	17,900	—
50	—	—	30,700	30,850	32,300	31,500	31,450	29,300	29,850	29,200	21,200	17,900	—
55	—	—	26,150	27,850	27,600	26,850	27,650	26,500	25,200	24,900	21,200	17,900	—
60	—	—	—	24,050	23,900	24,650	23,950	23,200	21,550	22,100	21,200	17,900	—
65	—	—	—	20,950	20,850	21,700	20,900	20,200	19,400	19,600	19,250	17,900	—
70	—	—	—	16,400	19,050	19,150	18,400	17,700	17,950	17,800	17,050	17,100	—
75	—	—	—	—	17,250	17,150	16,450	15,750	16,350	16,250	15,050	15,100	—
80	—	—	—	—	14,550	15,300	14,600	14,600	15,000	14,650	13,900	13,300	—
85	—	—	—	—	—	13,650	13,050	13,600	13,600	13,050	12,400	11,750	—
90	—	—	—	—	—	12,350	11,650	12,550	12,250	11,700	11,050	10,400	—
95	—	—	—	—	—	9,640	10,450	11,650	11,050	10,650	9,850	9,210	—
100	—	—	—	—	—	—	9,460	10,550	9,980	9,950	8,790	8,150	—
105	—	—	—	—	—	—	8,660	9,580	9,030	9,000	7,840	7,200	—
110	—	—	—	—	—	—	—	8,700	8,170	8,140	6,990	6,360	—
115	—	—	—	—	—	—	—	8,030	7,400	7,370	6,220	5,590	—
120	—	—	—	—	—	—	—	7,380	6,690	6,670	5,520	4,900	—
125	—	—	—	—	—	—	—	6,200	6,030	6,010	4,890	4,260	—
130	—	—	—	—	—	—	—	3,820	5,430	5,410	4,300	3,680	—
135	—	—	—	—	—	—	—	—	4,880	4,860	3,770	3,150	—
140	—	—	—	—	—	—	—	—	4,380	4,360	3,280	2,670	—
145	—	—	—	—	—	—	—	—	3,930	3,900	2,830	2,210	—
150	—	—	—	—	—	—	—	—	—	2,990	2,390	1,800	—
155	—	—	—	—	—	—	—	—	—	2,600	1,990	1,400	—
160	—	—	—	—	—	—	—	—	—	2,230	1,620	1,030	—
165	—	—	—	—	—	—	—	—	—	—	1,270	—	—

*Requires special equipment

THIS CHART IS ONLY A GUIDE AND SHOULD NOT BE USED TO OPERATE THE CRANE.
The individual crane's load chart, operating instructions and other instructional plates must be read and understood prior to operating the crane

Load chart

Main boom - MAXbase 20° over outriggers



37.2 ft - 197 ft



29,200 lb



100%



MAXbase



Pounds

Radius in feet	Main boom length in feet											
	37.2	49.9 - 50.8	60.5 - 64.4	73.6 - 78	84.5 - 91.3	98 - 104.4	109.3 - 117	122.9 - 137.7	147.9 - 154.1	156.3 - 169.9	183.4 - 184.1	194.7 - 196.9
8	180,000	—	—	—	—	—	—	—	—	—	—	—
10	176,500	177,500	160,000	—	—	—	—	—	—	—	—	—
12	158,000	159,000	145,000	125,000	—	—	—	—	—	—	—	—
15	136,000	137,000	129,500	114,000	100,500	—	—	—	—	—	—	—
20	105,000	105,500	105,000	95,700	85,750	80,250	—	—	—	—	—	—
25	80,950	83,550	82,600	81,400	75,600	69,250	65,350	—	—	—	—	—
30	—	65,500	66,450	66,100	64,900	62,800	58,700	53,500	—	—	—	—
35	—	53,350	53,950	53,750	55,150	54,850	52,950	48,950	36,600	—	—	—
40	—	44,550	44,800	45,250	46,150	47,400	46,250	43,850	36,600	29,350	—	—
45	—	—	39,200	39,550	39,150	40,550	39,400	38,450	35,800	29,350	21,200	—
50	—	—	33,650	34,050	33,750	35,050	34,050	33,100	32,750	29,200	21,200	17,900
55	—	—	29,200	29,600	30,900	30,600	29,600	28,750	29,250	27,250	21,200	17,900
60	—	—	—	26,000	27,450	26,900	27,300	25,150	25,700	25,150	21,200	17,450
65	—	—	—	24,100	24,350	23,850	24,750	22,200	22,700	22,150	20,850	16,650
70	—	—	—	18,350	21,750	21,650	22,100	20,450	20,150	19,750	19,650	15,900
75	—	—	—	—	19,450	20,400	19,850	18,900	17,900	18,050	18,550	15,150
80	—	—	—	—	17,500	18,450	17,900	17,300	16,000	17,000	16,800	14,400
85	—	—	—	—	—	16,750	16,150	15,600	15,050	15,300	15,100	13,550
90	—	—	—	—	—	15,200	14,650	14,050	14,150	13,750	13,600	12,700
95	—	—	—	—	—	—	12,400	13,250	12,700	13,150	12,400	11,900
100	—	—	—	—	—	—	—	12,050	11,450	11,950	11,250	11,100
105	—	—	—	—	—	—	—	10,950	10,800	10,950	10,500	9,950
110	—	—	—	—	—	—	—	—	10,250	10,300	9,800	9,120
115	—	—	—	—	—	—	—	—	9,740	9,720	9,150	8,200
120	—	—	—	—	—	—	—	—	8,970	8,890	8,450	7,800
125	—	—	—	—	—	—	—	—	8,210	8,330	7,840	7,250
130	—	—	—	—	—	—	—	—	4,900	7,630	7,140	6,550
135	—	—	—	—	—	—	—	—	—	6,980	6,490	5,910
140	—	—	—	—	—	—	—	—	—	6,380	6,080	5,310
145	—	—	—	—	—	—	—	—	—	5,820	5,730	4,750
150	—	—	—	—	—	—	—	—	—	—	4,810	4,230
155	—	—	—	—	—	—	—	—	—	—	4,320	3,740
160	—	—	—	—	—	—	—	—	—	—	3,530	3,280
165	—	—	—	—	—	—	—	—	—	—	—	2,860
170	—	—	—	—	—	—	—	—	—	—	—	2,450
175	—	—	—	—	—	—	—	—	—	—	—	2,070
180	—	—	—	—	—	—	—	—	—	—	—	1,120

THIS CHART IS ONLY A GUIDE AND SHOULD NOT BE USED TO OPERATE THE CRANE.
 The individual crane's load chart, operating instructions and other instructional plates must be read and understood prior to operating the crane

Load chart

Manual bi-fold extension



37.2 ft - 197 ft



35 ft



29,200 lb



100%



360°



Pounds

Radius in feet	35 ft boom extension								
	167.7 - 169.9 ft boom length			183.4 - 184.1 ft boom length			194.7 - 196.9 ft boom length		
	0° offset	20° offset	45° offset	0° offset	20° offset	45° offset	0° offset	20° offset	45° offset
40	12,800	—	—	—	—	—	—	—	—
45	12,800	—	—	11,650	—	—	—	—	—
50	12,800	—	—	11,650	—	—	10,050	—	—
55	12,800	13,350	—	11,650	—	—	10,050	—	—
60	12,800	13,350	—	11,650	12,050	—	10,050	—	—
65	12,800	13,350	11,350	11,650	12,050	—	10,050	10,350	—
70	12,800	12,950	11,150	11,650	12,050	11,300	10,050	10,350	—
75	12,450	12,200	10,950	11,650	12,050	11,100	10,050	10,350	10,800
80	11,550	11,450	10,750	11,650	12,050	10,900	10,050	10,350	10,800
85	10,750	10,800	10,600	11,100	12,050	10,750	10,050	10,350	10,750
90	10,000	10,100	10,300	10,250	10,700	10,550	9,780	10,350	10,600
95	9,300	9,450	9,720	9,260	9,830	10,200	8,600	9,470	10,250
100	8,670	8,820	9,150	8,200	8,950	9,590	7,540	8,350	9,060
105	7,960	8,240	8,540	7,260	7,950	8,530	6,600	7,350	8,000
110	7,100	7,680	7,970	6,410	7,050	7,580	5,760	6,460	7,040
115	6,330	6,860	7,260	5,640	6,240	6,710	5,000	5,650	6,180
120	5,630	6,120	6,470	4,950	5,500	5,930	4,310	4,910	5,390
125	5,000	5,450	5,760	4,320	4,830	5,210	3,680	4,240	4,680
130	4,420	4,830	5,100	3,740	4,210	4,550	3,100	3,630	4,020
135	3,880	4,260	4,490	3,210	3,650	3,940	2,570	3,060	3,410
140	3,390	3,740	3,930	2,720	3,120	3,390	2,090	2,540	2,850
145	2,940	3,250	—	2,270	2,640	2,870	1,640	2,060	2,340
150	2,520	2,800	—	1,850	2,190	2,390	1,220	1,610	1,860
155	2,130	2,390	—	1,460	1,780	—	—	1,200	1,410
160	1,770	2,000	—	1,100	1,390	—	—	—	—
165	1,440	1,630	—	—	1,030	—	—	—	—
170	1,130	1,290	—	—	—	—	—	—	—

THIS CHART IS ONLY A GUIDE AND SHOULD NOT BE USED TO OPERATE THE CRANE.

The individual crane's load chart, operating instructions and other instructional plates must be read and understood prior to operating the crane

Load chart

Manual bi-fold extension

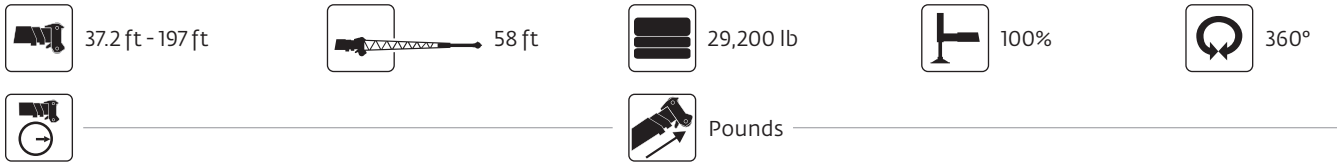

Radius in feet	58 ft boom extension								
	167.7 - 169.9 ft boom length			183.4 - 184.1 ft boom length			194.7 - 196.9 ft boom length		
	0° offset	20° offset	45° offset	0° offset	20° offset	45° offset	0° offset	20° offset	45° offset
45	8,090	—	—	—	—	—	—	—	—
50	8,090	—	—	7,570	—	—	—	—	—
55	8,090	—	—	7,570	—	—	6,640	—	—
60	8,090	—	—	7,570	—	—	6,640	—	—
65	8,090	—	—	7,570	—	—	6,640	—	—
70	8,090	7,080	—	7,570	—	—	6,640	—	—
75	8,090	6,940	—	7,570	6,940	—	6,640	—	—
80	8,090	6,810	5,690	7,570	6,820	—	6,640	6,660	—
85	8,090	6,680	5,620	7,570	6,700	5,660	6,640	6,560	—
90	8,000	6,570	5,560	7,570	6,590	5,600	6,640	6,470	—
95	7,830	6,450	5,500	7,570	6,490	5,540	6,640	6,370	5,520
100	7,650	6,340	5,440	7,570	6,390	5,480	6,640	6,290	5,480
105	7,490	6,240	5,380	7,260	6,290	5,430	6,640	6,200	5,430
110	7,080	6,140	5,330	6,810	6,190	5,370	6,170	6,120	5,390
115	6,610	6,040	5,280	6,030	6,100	5,330	5,390	6,040	5,340
120	6,020	5,950	5,240	5,330	5,970	5,280	4,690	5,830	5,300
125	5,370	5,870	5,210	4,690	5,660	5,250	4,060	5,120	5,260
130	4,780	5,600	5,180	4,100	5,010	5,210	3,470	4,470	5,220
135	4,240	5,000	5,130	3,560	4,420	5,150	2,940	3,870	4,690
140	3,740	4,450	5,020	3,060	3,870	4,540	2,440	3,320	4,080
145	3,280	3,940	4,450	2,610	3,360	3,970	1,990	2,820	3,500
150	2,860	3,470	3,920	2,180	2,890	3,440	1,570	2,340	2,970
155	2,460	3,030	3,420	1,790	2,450	2,940	1,180	1,900	2,480
160	2,090	2,620	2,950	1,420	2,040	2,480	—	1,490	2,010
165	1,750	2,230	2,510	1,080	1,650	2,040	—	1,110	1,580
170	1,430	1,870	—	—	1,290	1,630	—	—	1,170
175	1,130	1,530	—	—	—	1,240	—	—	—
180	—	1,210	—	—	—	—	—	—	—

THIS CHART IS ONLY A GUIDE AND SHOULD NOT BE USED TO OPERATE THE CRANE.
 The individual crane's load chart, operating instructions and other instructional plates must be read and understood prior to operating the crane

Load chart

Hydraulic bi-fold extension



37.2 ft - 197 ft



35 ft



29,200 lb



100%



360°



Pounds

Radius in feet	35 ft boom extension								
	167.7 - 169.9 ft boom length			183.4 - 184.1 ft boom length			194.7 - 196.9 ft boom length		
	0° offset	0° - 20° offset	20° - 45° offset	0° offset	0° - 20° offset	20° - 45° offset	0° offset	0° - 20° offset	20° - 45° offset
45	12,900	—	—	11,650	—	—	—	—	—
50	12,900	—	—	11,650	—	—	10,000	—	—
55	12,900	—	—	11,650	—	—	10,000	—	—
60	12,900	12,900	—	11,650	11,650	—	10,000	—	—
65	12,900	12,900	11,350	11,650	11,650	—	10,000	10,000	—
70	12,900	12,900	11,150	11,650	11,650	11,300	10,000	10,000	—
75	12,450	12,200	10,950	11,650	11,650	11,100	10,000	10,000	10,300
80	11,550	11,450	10,750	11,650	11,650	10,900	10,000	10,000	10,300
85	10,700	10,700	10,600	11,050	11,050	10,750	10,000	10,000	10,300
90	9,960	9,960	10,100	10,200	10,200	10,550	9,750	9,750	10,300
95	9,270	9,270	9,420	9,230	9,230	9,800	8,560	8,560	9,440
100	8,630	8,630	8,790	8,170	8,170	8,920	7,510	7,510	8,320
105	7,920	7,920	8,200	7,220	7,220	7,920	6,570	6,570	7,320
110	7,070	7,070	7,650	6,370	6,370	7,020	5,720	5,720	6,420
115	6,300	6,300	6,830	5,610	5,610	6,210	4,960	4,960	5,610
120	5,600	5,600	6,090	4,910	4,910	5,470	4,270	4,270	4,880
125	4,960	4,960	5,410	4,280	4,280	4,790	3,640	3,640	4,210
130	4,380	4,380	4,800	3,700	3,700	4,180	3,070	3,070	3,590
135	3,850	3,850	4,230	3,170	3,170	3,610	2,540	2,540	3,030
140	3,360	3,360	3,700	2,680	2,680	3,090	2,050	2,050	2,510
145	2,910	2,910	—	2,230	2,230	2,610	1,600	1,600	2,030
150	2,490	2,490	—	1,810	1,810	2,160	1,190	1,190	1,580
155	2,100	2,100	—	1,430	1,430	—	—	—	1,160
160	1,740	1,740	—	1,070	1,070	—	—	—	—
165	1,400	1,400	—	—	—	—	—	—	—
170	1,090	1,090	—	—	—	—	—	—	—

THIS CHART IS ONLY A GUIDE AND SHOULD NOT BE USED TO OPERATE THE CRANE.

The individual crane's load chart, operating instructions and other instructional plates must be read and understood prior to operating the crane

Load chart

Hydraulic bi-fold extension

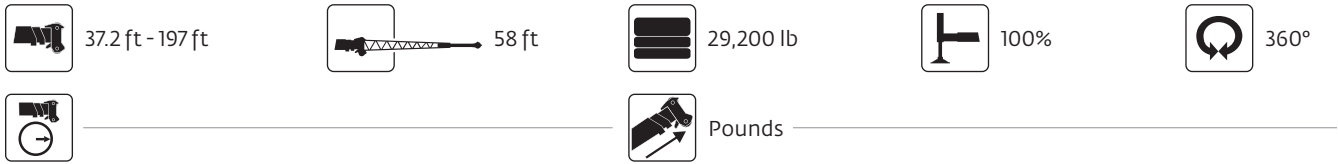

Radius in feet	58 ft boom extension								
	167.7 - 169.9 ft boom length			183.4 - 184.1 ft boom length			194.7 - 196.9 ft boom length		
	0° offset	0° - 20° offset	20° - 45° offset	0° offset	0° - 20° offset	20° - 45° offset	0° offset	0° - 20° offset	20° - 45° offset
45	8,070	—	—	—	—	—	—	—	—
50	8,070	—	—	7,550	—	—	—	—	—
55	8,070	—	—	7,550	—	—	6,620	—	—
60	8,070	—	—	7,550	—	—	6,620	—	—
65	8,070	—	—	7,550	—	—	6,620	—	—
70	8,070	7,070	—	7,550	—	—	6,620	—	—
75	8,070	6,940	—	7,550	6,930	—	6,620	—	—
80	8,070	6,810	5,500	7,550	6,810	—	6,620	6,620	—
85	8,070	6,680	5,440	7,550	6,700	5,470	6,620	6,560	—
90	8,000	6,560	5,380	7,550	6,590	5,410	6,620	6,470	—
95	7,820	6,440	5,320	7,550	6,480	5,360	6,620	6,370	5,360
100	7,650	6,310	5,270	7,550	6,380	5,310	6,620	6,280	5,320
105	7,480	6,180	5,230	7,240	6,290	5,260	6,620	6,200	5,270
110	7,050	6,070	5,190	6,770	6,170	5,220	6,130	6,110	5,230
115	6,580	5,950	5,150	6,000	6,000	5,180	5,360	5,360	5,190
120	5,990	5,840	5,120	5,300	5,300	5,150	4,660	4,660	5,150
125	5,340	5,340	5,090	4,650	4,650	5,110	4,020	4,020	5,090
130	4,750	4,750	5,070	4,070	4,070	4,990	3,440	3,440	4,440
135	4,210	4,210	4,980	3,530	3,530	4,390	2,910	2,910	3,850
140	3,710	3,710	4,420	3,030	3,030	3,840	2,410	2,410	3,300
145	3,250	3,250	3,910	2,580	2,580	3,330	1,960	1,960	2,790
150	2,830	2,830	3,440	2,150	2,150	2,860	1,540	1,540	2,310
155	2,430	2,430	3,000	1,760	1,760	2,420	1,140	1,140	1,880
160	2,060	2,060	2,590	1,390	1,390	2,010	—	—	1,470
165	1,720	1,720	2,200	1,050	1,050	1,620	—	—	1,080
170	1,400	1,400	—	—	—	1,260	—	—	—
175	1,100	1,100	—	—	—	—	—	—	—

THIS CHART IS ONLY A GUIDE AND SHOULD NOT BE USED TO OPERATE THE CRANE.
 The individual crane's load chart, operating instructions and other instructional plates must be read and understood prior to operating the crane

Load chart

Pick and carry



37.2 - 86.6 ft



29,200 lb



Pick and carry
Up to 1 mph
29.5 x 25 tires



Boom
over front

Boom centered over front						
Radius in feet	Main boom length in feet					
	37.2	49.9	60.5	62.6	75.6	86.6
Tele I	0%	0%	0%	0%	0%	0%
Tele II	0%	0%	0%	0%	0%	0%
Tele III	0%	0%	0%	0%	0%	0%
Tele IV	0%	0%	0%	0%	0%	0%
Tele V	0%	0%	0%	0%	50%	92%
Tele VI	0%	50%	92%	100%	100%	100%
Mode	All	1, 2, 3, 4	1, 2	1	1	1
12	49,400	43,000				
15	41,300	40,000	38,000	38,000		
20	32,000	34,250	32,000	32,000	27,000	24,000
25	24,000	27,550	28,000	28,000	24,000	22,500
30		21,750	23,200	23,150	22,500	21,500
35		17,650	19,550	19,500	21,000	20,300
40		14,500	15,750	16,000	17,750	17,550
45			13,100	13,350	15,050	15,100
50			10,950	11,200	12,700	12,950
55				9,370	10,650	11,050
60					8,910	9,330
65					7,350	7,770
70						6,350
75						5,060
Minimum boom angle (°) for indicated length (no load)						0°
Maximum boom length at 0° boom angle (no load) -						86.6 ft

NOTES FOR PICK & CARRY ON RUBBER

1. Capacities are in pounds and do not exceed 75% of tipping loads as determined by test in accordance with SAE J765.
2. Capacities are applicable to machines equipped with Titan ND LCM MCS - 29.5x25 (34 ply) tires at 76 psi (5.2 bar) cold inflation pressure.
3. Capacities are applicable only with the machine on a firm level surface.
4. On rubber lifting with boom extension not permitted.
5. For pick and carry operation, boom must be centered over front of machine, mechanical swing lock engaged, and load restrained from swinging.
6. Axle lockouts must be functioning when lifting on rubber.
7. All lifting depends on proper tire inflation, capacity and condition. Capacities must be reduced for lower tire inflation pressures. See the tire inflation table for tire specifications. Damaged tires are hazardous to safe operation of crane.
8. Creep - not over 200 ft (61 m) of movement in any 30 minute period and not exceeding 1 mph (1.6 km/h).

Boom angle	Lifting capacities at 0° boom angle					
	37.2	49.9	60.5	62.6	75.6	86.6
Mode	All	1,2,3,4	1,2	1	1	1
0°	18,450	13,300	9,830	9,360	6,500	4,110

*THIS CHART IS ONLY A GUIDE AND SHOULD NOT BE USED TO OPERATE THE CRANE.
The individual crane's load chart, operating instructions and other instructional plates must be read and understood prior to operating the crane*

Load chart

Stationary



37.2 - 86.6 ft



29,200 lb



Stationary



360°

Stationary capacities						
Radius in feet	Main boom length in feet					
	37.2	49.9	60.5	62.6	75.6	86.6
Tele I	0%	0%	0%	0%	0%	0%
Tele II	0%	0%	0%	0%	0%	0%
Tele III	0%	0%	0%	0%	0%	0%
Tele IV	0%	0%	0%	0%	0%	0%
Tele V	0%	0%	0%	0%	50%	92%
Tele VI	0%	50%	92%	100%	100%	100%
Mode	All	1, 2, 3, 4	1, 2	1	1	1
20	31,000					
25	20,600	23,500				
30		17,150	19,300	19,550		
35		12,800	14,800	15,000	16,700	17,100
40		9,660	11,450	11,700	13,300	13,750
45			8,920	9,230	10,750	11,150
50			6,890	7,240	8,730	9,150
55				5,640	7,110	7,520
60					5,780	6,160
65					4,670	5,030
70						4,070
75						3,230
Minimum boom angle (°) for indicated length (no load)						0°
Maximum boom length at 0° boom angle (no load)						86.6 ft

NOTES FOR STATIONARY ON RUBBER

1. Capacities are in pounds and do not exceed 75% of tipping loads as determined by test in accordance with SAE J765.
2. Capacities are applicable to machines equipped with Titan ND LCM MCS - 29.5x25 (34 ply) tires at 76 psi (5.2 bar) cold inflation pressure.
3. Capacities are applicable only with the machine on a firm level surface.
4. On rubber lifting with boom extension not permitted.
5. Axle lockouts must be functioning when lifting on rubber.
6. All lifting depends on proper tire inflation, capacity and condition. Capacities must be reduced for lower tire inflation pressures. See the tire inflation table for tire specifications. Damaged tires are hazardous to safe operation of crane.

Boom angle	Lifting capacities at 0° boom angle					
	37.2	49.9	60.5	62.6	75.6	86.6
Mode	All	1,2,3,4	1,2	1	1	1
0°	14,650	8,440	5,840	5,620	4,070	2,640

*THIS CHART IS ONLY A GUIDE AND SHOULD NOT BE USED TO OPERATE THE CRANE.
The individual crane's load chart, operating instructions and other instructional plates must be read and understood prior to operating the crane*

Rigging charts

Rigging chart for installation and removal of counterweight, on outriggers fully extended				
Radius in feet	Main boom length in feet			
	37.2	49.9	62.9	76.4
Tele I	0%	50%	0%	0%
Tele II	0%	0%	0%	0%
Tele III	0%	0%	0%	0%
Tele IV	0%	0%	0%	50%
Tele V	0%	0%	50%	50%
Tele VI	0%	50%	50%	50%
Mode	All	1, 2, 3, 4	3	3
10	170,500	77,500	84,050	
12	145,500	71,750	76,950	
15	118,000	64,550	68,200	75,400
20	82,500	55,400	57,250	63,100
25	55,550	48,650	49,100	54,100
30		41,550	42,850	44,450
35		30,750	32,800	33,400
40		23,300	25,550	26,100
45			20,450	21,000
50			16,550	17,150
55			13,500	14,350
60				11,900
65				9,950
Minimum boom angle (°) for indicated length (no load)				0°
Maximum boom length at 0° boom angle (no load)				76.4

Loading and unloading - on rubber (0 lb counterweight)	
Radius in feet	Main boom length in feet
	37.2
Tele I	0%
Tele II	0%
Tele III	0%
Tele IV	0%
Tele V	0%
Tele VI	0%
Mode	All
12	5400
15	5400
20	5400
25	5400
Boom angle	Lifting capacities at 0° boom angle
	37.2
Mode	All
0°	5400

NOTE: For loading and unloading, the boom must be centered over front of machine and mechanical swing lock engaged. Hookblock and overhaul weight/ball must be restrained from swinging.

Boom angle	Lifting capacities at 0° boom angle			
	37.2	49.9	62.9	76.4
Mode	All	1, 2, 3, 4	3	3
0°	30,850	20,600	13,300	8,680

THIS CHART IS ONLY A GUIDE AND SHOULD NOT BE USED TO OPERATE THE CRANE. The individual crane's load chart, operating instructions and other instructional plates must be read and understood prior to operating the crane

Load handling

Weight reductions for load handling devices	
Auxiliary boom nose	88 kg (194 lb)
Hook blocks and overhaul weights:	
100 t (112 USt), 7-sheave	1140 kg (2513 lb)+
75 t (83 USt), 5-sheave	1070 kg (2359 lb)+
45 t (50 USt), 3-sheave	770 kg (1698 lb)+
26 t (29 USt), single sheave	535 kg (1179 lb)+
11 t (12 USt), overhaul weight	294 kg (648 lb)+
9 t (10 USt), overhaul ball	330 kg (727 lb)+

*Refer to rating plate for actual weight.

Line pulls and reeving information			
Hoists	Cable specs.	Permissible line pulls	Nominal cable length
Main	19 mm (3/4 in) 35x7 Class rotation resistant (non-rotating) Min. breaking strength 38 918 kg (85,800 lb)	7784 kg (17,160 lb)*	250 m (820 ft)
Auxiliary	19 mm (3/4 in) 35x7 Class rotation resistant (non-rotating) Min. breaking strength 38 918 kg (85,800 lb)	7784 kg (17,160 lb)*	185 m (607 ft)

The approximate weight of 19 mm (3/4 in) wire rope is 1.93 kg/m (1.3 lb/ft).
*With certain boom and hoist tackle combinations, the allowable line pull may be limited by hoist performance. Refer to Hoist performance table for lift planning to ensure adequate hoist performance on drum rope layer required.

Hoist performance				
Wire rope layer	Hoist line pulls		Drum capacity (ft)	
	Two speed hoist		Layer	Total
	Low	High		
	Available lb	Available lb		
1	23,468	12,962	108.7	108.7
2	21,553	11,904	118.4	227.1
3	19,927	11,006	128.1	355.2
4	18,530	10,234	137.7	492.9
5	17,315	9563	147.4	640.3
6	16,250	8975	157.1	797.4

*Refer to Line Pulls and Reeving Information table for max. lifting capacity of wire rope.

Synthetic rope layer height may vary and may reduce available line pull per layer.

Tire inflation		
Size (front and rear)	TRA Code	Lifting service, general travel and extended travel
		Static, creep and 2.5 mph (4.0 km/h)
29.5 x 25 - 34 PR	E-3/L-3	5.2 bar (76 psi)

Working area diagram

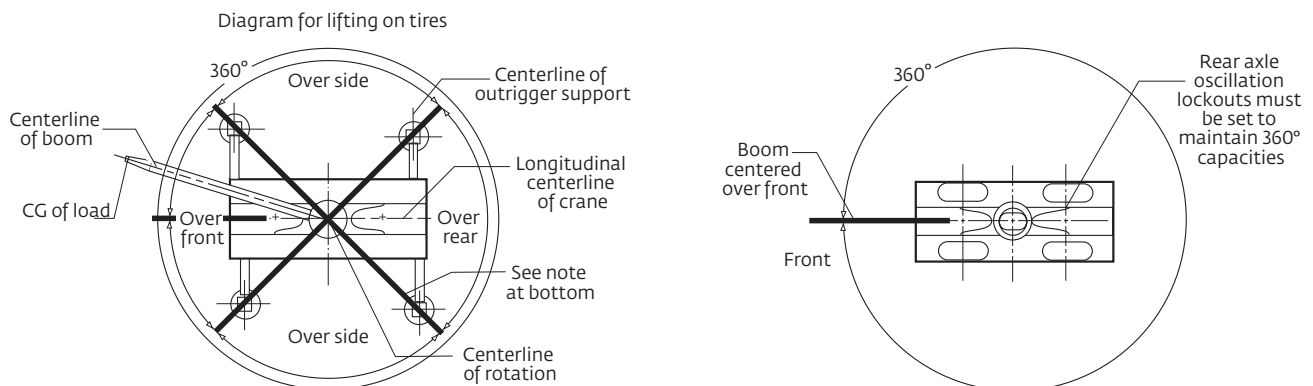

Bold lines determine the limiting position of any load for operation within working areas indicated.

THIS CHART IS ONLY A GUIDE AND SHOULD NOT BE USED TO OPERATE THE CRANE.

The individual crane's load chart, operating instructions and other instructional plates must be read and understood prior to operating the crane

Specifications

Superstructure

Boom

BOOM: 11,3 m - 60 m (37.2 ft - 197 ft) seven-section MEGAFORM™ boom with TWIN-LOCK™ boom pinning system.
Maximum tip height: 63.1 m (207 ft)

Boom nose

Five nylon sheaves mounted on heavy-duty tapered roller bearings with removable pin type guards. Quick reeve boom nose. Removable single sheave auxiliary boom nose with removable pin-type rope guard.

Boom elevation

Single hydraulic cylinder with integral holding valve provides boom elevation from -3° to +80°.

Manual bi-fold swingaway extension*

10,5 m - 17,6 m (34.5 ft - 57.6 ft) bi-fold lattice swingaway extension. Offsets at 0°, 20° and 45°. Stows alongside base boom section. Includes wireless rigging remote.
Maximum tip height: 80.8 m (265 ft)

Hydraulic bi-fold swingaway extension*

10,5 m - 17,6 m (34.5 ft - 57.6 ft) bi-fold lattice swingaway extension. Hydraulically offsets from 0° to 45°. Controlled from crane cab. Stows alongside base boom section. Includes wireless rigging remote.
Maximum tip height: 80.8 m (265 ft)

Crane Control System (CCS)

Rated Capacity Limiter (RCL) with graphical display. Load moment and anti-two block system with audio-visual warning and control lever lockout. This system provides electronic display of boom angle, boom length, load radius, boom tip height, maximum permissible load, actual load and warning of impending two-block condition. Also includes an Operating display which shows the crane operating indicators, levels, warnings and faults. Other features include a Working Range Limiter (WRL) which allows the operator to preselect and define working areas. If the crane approaches the operator preset limits, audio-visual warnings aid the operator in avoiding obstructions. ECO mode system to control engine rpm to lower noise and improve fuel consumption. Operator-programmable function speeds and ramps.

Cab

Operator-controlled 20° hydraulic cab tilt, full vision; all steel, galvanealed construction with acoustical lining and tinted safety glass throughout. Deluxe seat with electronic seat controls and headrest, incorporates armrest-mounted electronic programmable single-axis or dual-axis controllers and a jog dial for easy data input. Tilt/telescoping steering wheel with controls incorporated into the steering column. Other standard features include heater (hot water), circulating air fan, high-output air conditioning system, sliding skylight with sunscreen, windshield and skylight washer/wiper, windshield sun visor, fire extinguisher, seat belt, USB charging port, pivoting cup holder, and dual cab-mounted LED work lights.

Swing

Variable speed, 360° continuous rotation. Planetary swing drive with foot actuated multi-disc brake. Spring-applied, hydraulically released swing brake. Two-position mechanical swing lock pin, operated from cab.
Maximum speed: 2 rpm

Counterweight

13 245 kg (29,200 lb) hydraulically installed and removed. Controls located on both sides of superstructure.

Hoist (main and optional auxiliary hoist)

Planetary reduction driven by axial piston motor. Grooved drum with automatic spring applied multi-disc wet brake. Electronic hoist drum rotation indicator. Third wrap indicator with hoist function cut-off standard.

Maximum hoist single line pull:

1st layer: 10 645 kg (23,468 lb)

3rd layer: 9039 kg (19,927 lb)

6th layer: 7371 kg (16,250 lb)

Maximum permissible single line pull:

7784 kg (17,160 lb)

Maximum hoist single line speed (no load):

148 m/min (487 ft/min)

Rope construction:

35 x 7 rotation - resistant

Rope diameter:

19 mm (3/4 in)

Rope length:

Main hoist: 250 m (820 ft)

Auxiliary hoist: 185 m (607 ft)

Carrier

Chassis

Parallel box section fabricated from high-strength, low-alloy steel with integral outrigger boxes, front and rear lift, tie-down, and towing lugs.

Outrigger system

Four hydraulic telescoping single stage double box beam outriggers with inverted jack cylinders and integral jack holding valves. Three position settings, 0%, 50%, and fully extended. Polymer outrigger floats 600 mm (23.6 in) diameter. Outrigger Monitoring System (OMS) with in-cylinder sensors. Outrigger beam position shown on RCL display.

Outrigger controls

Main controls and digital level shown on operating display in cab. Extension and retraction are through the CCS system as well as the wireless rigging remote. Includes automatic leveling feature.

* Denotes optional equipment

Carrier *cont'd*



Hydraulic system

Two main pumps variable displacement piston and one gear with a combined output capacity of 507 L/min (134 gal/min).
Maximum operating pressure: 276 bar (4000 psi)
Return line in-tank filter with full flow by-pass protection and service indicator.
Replaceable cartridge with 4 micron filtration rating per ISO cleanliness level of 17/15/12. Carrier mounted oil cooler with thermostatically controlled hydraulic motor driven fan / air to oil. System pressure test ports.



Engine (Tier 4F)

Cummins QSB6, 7L diesel six cylinder, turbo-charged with Cummins Compact Catalyst (CCC) and selective catalytic reduction (SCR) combo muffler, using diesel exhaust fluid (DEF) injection. Meets emissions per U.S. EPA Tier 4F and E.U. Stage IV.
275 hp (205 kW) at 2500 rpm, Maximum torque: 730 lb/ft (990 Nm) at 1500 rpm. Fuel requirements: Maximum of 15 ppm ultra-low sulfur diesel fuel + diesel exhaust fluid (DEF).



Engine (Tier 3)

Cummins QSB6, 7L diesel six cylinder, turbo-charged with 275 hp (205 kW) at 2500 rpm, Maximum torque: 730 lb/ft (990 Nm) at 1500 rpm. Fuel requirements: Maximum of 5000 ppm. Sulfur diesel fuel.



Fuel tank capacity

271 L (72 gal)



Transmission

Rangeshift with six forward and six reverse speeds.
(Three speeds high and three speeds low). Front axle disconnect for 4 x 2 drive.



Axles

FRONT: Drive / steer with differential and planetary reduction hubs rigid mounted to frame.
REAR: Drive / steer with differential and planetary reduction hubs pivot mounted to frame. Automatic full hydraulic lockouts on rear axle permits 254 mm (10 in) of oscillation only with boom centered over the front.



Brakes

Full hydraulic split (dual) circuit dry disc operating on all wheels with dual calipers. High pressure parking brake is spring applied / hydraulically released on the front axle input shaft.



Steering

Fully independent power steering.
Front: Fully hydraulic steering wheel controlled.
Rear: Fully hydraulic via separate momentary switch provides infinite variations 4 steering modes, front only, rear only, coordinated and crab.
Rear steer not aligned indicator.
Outside 4WS coordinated steer radius: 7,5 m (24.6 ft)
Inside 4WS coordinated steer radius: 4,8 m (15.8 ft)



Tires

29.5 x 25 - 34 bias ply rating



Electrical system

Two 12 V maintenance-free batteries with disconnect.
24 V system / 24 V lighting



Lighting

Full LED lighting package including turn indicators; head, tail, brake and hazard warning lights; carrier side mounted work lights and work lights mounted on cab front.



Maximum Drive Speed

24,1 km/h (15 mph) with counterweight installed.



Gradeability (theoretical)

99% to drive train stall based on 59 017 kg (130,111 lb) GVW with 29.5 x 25 tires, standard counterweight, auxiliary hoist and manual bi-fold extension.

Miscellaneous standard equipment

Full length aluminum decking, dual rear view mirrors, hook block tie-down, electronic back-up alarm, covered deck storage compartment, hot water cab heater / defroster, cab air conditioner, hourmeter, A/V warning system, combination lift/tie-down/towing lugs, coolant sight level indicator, hoist access platform, storage boxes on both sides of carrier and cribbing storage on left side of carrier.

*Optional equipment

- **Auxiliary Hoist Package:** Includes auxiliary hoist with electronic hoist drum rotation indicator, third wrap indicator with hoist function cut-out, 185 m (607 ft) of 19 mm (¾ in.) of 35 x 7 class rotation resistant wire rope.
- **Auxiliary Lighting and Convenience Package:** Includes superstructure mounted amber flashing beacon, dual base boom mounted LED work lights controlled from cab and in-cab RCL light bar.
- 10,5 m - 17,6 m (34.5 ft - 57.6 ft) manual bi-fold swingaway extension
- 10,5 m - 17,6 m (34.5 ft - 57.6 ft) hydraulic luffing extension
- 360° positive swing lock
- Rear pintle hitch
- Cab-controlled cross axle differential locks (front and rear)
- Wind speed indicator
- Boom mounted, boom position indicator light
- Vertical RCL light tower
- -29C / -20F cold weather package
- -40C / -40F arctic weather package
- Emergency stop buttons on each side of carrier
- Second beacon light
- Refinery package (certified spark arrestor + engine air shutdown) (T3 engine only)
- MAXbase - variable outrigger positioning system
- Three camera package (rear-view, right side and hoists)
- Bluetooth/AM/FM radio
- Heated seat
- CraneSTAR asset management system

* Denotes optional equipment

Symbols glossary



Axles



Counterweight



Hydraulic system



Speed



Boom



Crane control system



Insert



Steering



Boom elevation



Electrical system



Lights



Suspension



Boom extension



Engine



MAXbase



Swing



Boom nose

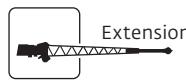

Extension



Outrigger controls



Tires



Brakes



Fuel tank capacity



Outriggers



Transmission



Cab



Grade



Radius



Chassis



Hoist



Rotation

Notes

Manitowoc Cranes

Regional headquarters

Americas

Milwaukee, Wisconsin, USA

Tel: +1 414 760 4600

Shady Grove, Pennsylvania, USA

Tel: +1 717 597 8121

Europe and Africa

Dardilly, France - TOWERS

Tel: +33 (0) 4 72 18 20 20

Wilhelmshaven, Germany - MOBILE

Tel: +49 (0) 4421 294 0

APAC

Shanghai, China

Tel: +86 21 6457 0066

Singapore

Tel: +65 6264 1188

Middle East and India

Dubai, UAE

Tel: +971 4 8862677



This document is non-contractual. Constant improvement and engineering progress make it necessary that we reserve the right to make specification, equipment, and price changes without notice. Illustrations shown may include optional equipment and accessories and may not include all standard equipment.